

## Capri Raised Pergola with Floor

ITM. / ART. 2002440

**IMPORTANT, RETAIN FOR FUTURE REFERENCE: READ CAREFULLY**  
**THIS ITEM IS INTENDED FOR OUTDOOR DOMESTIC USE ONLY.**  
**NOT FOR COMMERCIAL USE.**

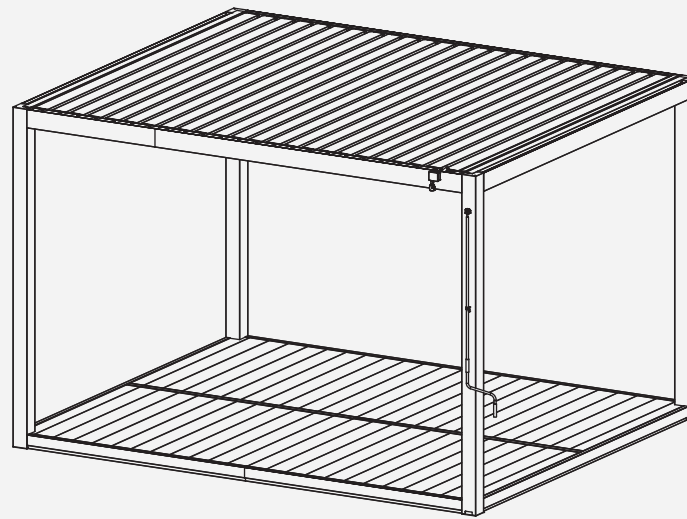

### Questions, problems, missing parts?

Before returning to your retailer, call our Customer Service Department at 1-888-690-9800 (8:00 am - 5:00 pm PT, Monday - Friday, English and Spanish) or email us at [service@sunvilla.com](mailto:service@sunvilla.com).

### Preparation

Before beginning to assemble this product, make sure all parts are present. Compare parts with package contents list and hardware contents list. If any parts are missing or damaged, do not attempt to assemble this product. Stop and call our Customer Service Center.

Estimated Assembly Time: 6 hours (3 persons). Tools Required for Assembly: Hex Wrench, Wrench, Phillips Screwdriver (included).

### **⚠ Safety Information**

Please read and understand this entire manual before attempting to assemble or install the product. It should not be used as a toy or tool. Children should not engage in the operation, assembly, removal, or disassembly of the product.

## *Table of Contents / Table des matières / Tabla de Contenido*

---

<b>Care &amp; Maintenance</b>	<b>3</b>
<b>Entretien et maintenance</b>	<b>5</b>
<b>Cuidados y mantenimiento</b>	<b>7</b>
<hr/>	
<b>Warranty</b>	<b>3</b>
<b>Garantie</b>	<b>5</b>
<b>Garantía</b>	<b>7</b>
<hr/>	
<b>Structure Parts List</b>	
<b>Liste des pièces de la structure</b>	<b>8</b>
<b>Lista de piezas de la estructura</b>	
<hr/>	
<b>Tools Required</b>	
<b>Outils requis</b>	<b>14</b>
<b>Herramientas necesarias</b>	
<hr/>	
<b>Structure Assembly</b>	
<b>Montage de la structure</b>	<b>15</b>
<b>Ensamble de la estructura</b>	
<hr/>	
<b>Structure Operation</b>	
<b>Fonctionnement de la structure</b>	<b>71</b>
<b>Funcionamiento de la estructura</b>	
<hr/>	

## *Care and Maintenance*

---

### **Frame**

Hand wash with mild soap and rinse thoroughly with water. Dry with a soft cloth. Do not use abrasive cleaners or scrub too rough as it may mar the surface.

During snowy conditions, accumulated snow must be removed from the roof to prevent damage.

## *Warranty*

---

### **2 YEAR LIMITED WARRANTY\***

This product is covered under a manufacturer's 2 year warranty from the date of purchase against defects in materials and workmanship. This warranty does not cover damage due to neglect, abuse, or weather related damage.

AUSTRALIA: Our goods come with guarantees that cannot be excluded under the Australian Consumer Law. You are entitled to a replacement or refund for a major failure and for compensation for any other reasonably foreseeable loss or damage. You are also entitled to have the goods repaired or replaced if the goods fail to be of acceptable quality and the failure does not amount to a major failure.

For warranty disclosure, email us at: [service@sunvilla.com](mailto:service@sunvilla.com) or chat with us at <https://sunvilla.com>.

## Pergola surélevée Capri avec plancher

ITM. / ART. 2002440

**IMPORTANT, À CONSERVER POUR DE FUTURS BESOINS DE RÉFÉRENCE : À LIRE SOIGNEUSEMENT**  
**CET ARTICLE EST DESTINÉ À UN USAGE DOMESTIQUE EXTÉRIEUR UNIQUEMENT.**  
**NON CONÇU POUR UNE UTILISATION COMMERCIALE.**

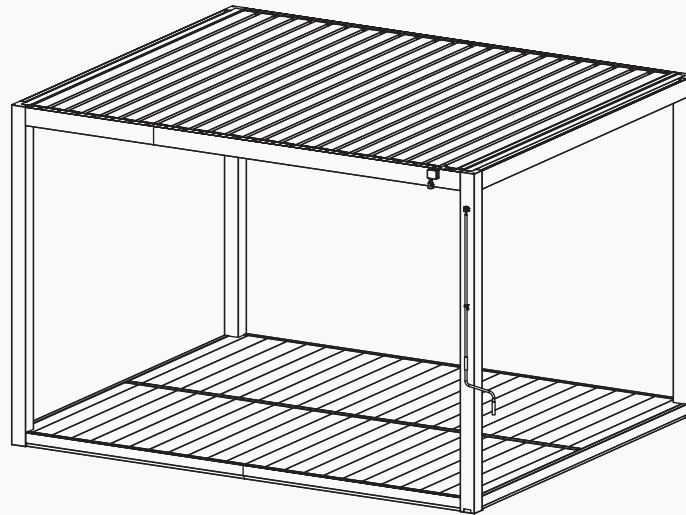

### Questions ? Pièces manquantes ?

Avant de retourner chez le détaillant, communiquer avec le service à la clientèle au 1-888-690-9800, en semaine, entre 8 h et 17 h (heure du Pacifique) ou entre 11 h et 20 h (heure de l'Est), ou écrire à [service@sunvilla.com](mailto:service@sunvilla.com). Service en anglais et en espagnol.

### Préparation

Avant de commencer le montage, vérifier qu'il ne manque aucune pièce. Comparer le contenu de l'emballage avec la liste des pièces et de la quincaillerie. Si une pièce manque ou est brisée, ne pas assembler le produit; appeler le service à la clientèle.

Temps d'assemblage estimé : 6 heures (3 personnes). Outils requis : Clé, Clé hexagonale, Tournevis à pointe cruciforme (comprise).

### **⚠** Consignes de sécurité

Lire attentivement le présent guide avant de commencer l'assemblage du produit. Ce n'est ni un jouet ni un outil. Les enfants ne doivent pas actionner, assembler, déplacer ou démonter le produit.

## *Entretien et maintenance*

---

### **Cadre**

Laver à la main avec du savon doux et rincer abondamment à l'eau. Séchez avec un chiffon doux. N'utilisez pas de nettoyeurs abrasifs et ne frottez pas trop rugueux car cela pourrait abîmer la surface.

Par temps de neige, la neige accumulée doit être enlevée du toit pour éviter tout dommage.

## *Garantie*

---

### **GARANTIE LIMITÉE DE 2 ANS\***

Ce produit est couvert par une garantie du fabricant de 2 ans à partir de la date d'achat, qui couvre les défauts de matériaux et de fabrication. Cette garantie exclut les dommages causés par la négligence, l'utilisation abusive ou les conditions climatiques.

AUSTRALIE : Nos articles sont offerts avec des garanties qui ne peuvent connaître d'exclusions au regard de la loi australienne sur la protection des consommateurs. Vous avez droit au remplacement ou au remboursement en cas de défaillance majeure de votre article ainsi qu'à une compensation en cas de perte ou de dommage prévisible. Vous avez aussi droit à la réparation ou au remplacement de l'article s'il n'est pas d'une qualité acceptable et que la défaillance n'est pas majeure.

Pour obtenir la garantie, communiquer avec nous par courriel à [service@sunvilla.com](mailto:service@sunvilla.com), ou par clavardage sur <https://sunvilla.com>.

## Pérgola elevada Capri con piso

ITM. / ART. 2002440

**IMPORTANTE: CONSERVE PARA FUTURA REFERENCIA. LEA  
CUIDADOSAMENTE**

**ESTE ARTÍCULO ES PARA USO DOMÉSTICO EN EXTERIORES SOLAMENTE.  
NO ES PARA USO COMERCIAL.**

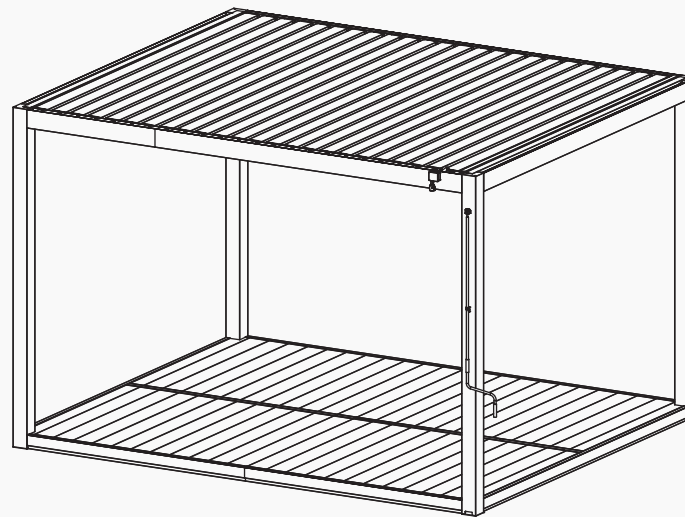

### ¿Preguntas, problemas o piezas faltantes?

Antes de regresar el producto a la tienda, llame a nuestro departamento de Servicio al Cliente al 1-888-690-9800 o envíe un correo electrónico a [service@sunvilla.com](mailto:service@sunvilla.com), de lunes a viernes, de 8:00 am a 5:00 pm, hora del Pacífico de E.U.A o de 11:00 am a 8:00 pm, hora del Este de E.U.A. Inglés y español. Teléfono no válido en México.

### PREPARACIÓN

Antes de comenzar a ensamblar este producto, asegúrese que todas las piezas estén completas. Compare las piezas con el listado de contenido de piezas y de herramientas del empaque. No intente ensamblar el producto si faltase alguna pieza o si estuviera dañada. Si así fuera, no continúe y llame a nuestro centro de servicio al cliente. Tiempo estimado de ensamble: 6 horas (3 personas). Herramientas requeridas para el ensamble: Inglesa, Llave hexagonal, Destornillador Phillips (incluido).

### **⚠ INFORMACIÓN DE SEGURIDAD**

Por favor lea con atención este manual completo antes de ensamblar o instalar el producto. Los niños no deben participar en la operación, el ensamblaje, remoción o desmontaje del producto.

## *Cuidados y mantenimiento*

---

### **Marco**

Lavar a mano con jabón suave y enjuagar bien con agua. Secar con un paño suave. No utilice limpiadores abrasivos ni friegue demasiado rugoso ya que puede dañar la superficie.

Durante condiciones de nieve, se debe eliminar la nieve acumulada desde el techo para evitar daños.

## *Garantía*

---

### **2 AÑOS DE GARANTÍA LIMITADA\***

Este producto está cubierto por una garantía del fabricante de 2 años a partir de la fecha de compra contra defectos de materiales y mano de obra. Esta garantía no cubre daños debidos a negligencia, abuso o daños relacionados con el clima.

AUSTRALIA: Nuestros productos cuentan con garantías que no se pueden excluir bajo las Leyes del Consumidor de Australia. Usted tiene derecho a un cambio o devolución en caso de un fallo importante y a una compensación por cualquier otra pérdida o daño razonablemente previsible. También tiene derecho a la reparación o reemplazo de los bienes, si éstos no cumplen con una calidad aceptable y el fallo no constituye un fallo importante.

Para obtener información sobre la garantía, envíenos un correo electrónico a [service@sunvilla.com](mailto:service@sunvilla.com) o chatee con nosotros en <https://sunvilla.com>.

# Structure Parts List / Liste des pièces de la structure / Lista de piezas de la estructura

**⚠ WARNING:** Perform all assembly steps on a flat, soft, non-abrasive surface to avoid scratching the finish.

**⚠ AVERTISSEMENT :** Pour éviter d'endommager votre nouveau parapluie, veuillez utiliser le carton ou un autre surface douce telle qu'un tapis comme surface de travail pour éviter d'endommager le produit lors de l'assemblage.

**⚠ WARNING:** Para evitar daños a su nuevo paraguas, utilice la caja de cartón u otra superficie blanda, como una alfombra, como superficie de trabajo para evitar daños al producto durante el montaje.



Estimated Assembly Time: 180 minutes  
 Recommended: 3 people  
 Temps de montage estimé : 180 minutes  
 Recommendation : 3 personnes  
 Tiempo estimado de ensamble duración: 180 minutos  
 Recomendado: 3 personas











Hand tighten  
 Serrer à la main  
 Apretar a mano

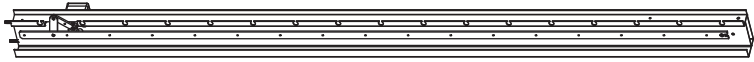

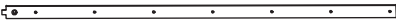
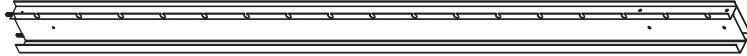



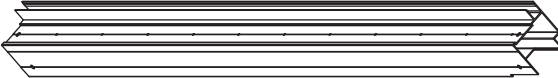



Fully tighten  
 Serrer complètement  
 Apretar completamente

	PARTS LIST LISTE DES PIÈCES LISTA DE PIEZAS	DESCRIPTION DESCRIPTION DESCRIPCIÓN	QTY QTÉ CANT	CARTON# CARTON# CAJA#
1		Post 1 Poteau 1 Poste 1	3	1
2		Foot Plate Plaque d'assise Placa de pie	4	1
3		Post 2 Poteau 2 Poste 2	1	1
4		Short Beam Poutre courte Viga corta	2	1
5		Beam Inner Tube Tube intérieur de poutre Tubo interior de viga	2	1

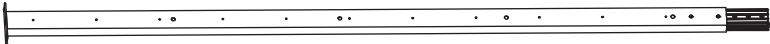



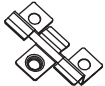
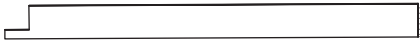

# Structure Parts List / Liste des pièces de la structure / Lista de piezas de la estructura

	PARTS LIST LISTE DES PIÈCES LISTA DE PIEZAS	DESCRIPTION DESCRIPTION DESCRIPCIÓN	QTY QTÉ CANT	CARTON# CARTON# CAJA#
6		Right Beam Poutre droite Viga derecha	1	1
7		Linkage Bar Connector Connecteur de barre de liaison Conector de barra de enlace	1	1
8		Linkage Bar Barre de liaison Barra de enlace	1	1
9		Left Beam Poutre gauche Viga izquierda	1	2
10		Front/back Beam Poutres avant et arrière Viga delantera/trasera	2	2
11		Sealing of Post Capuchon de poteau Sellado del poste	4	2
12		Long Side Outer Frame 1 Cadre extérieur côté long 1 Marco exterior del lado largo 1	2	2
13		Long Side Outer Frame 2 Cadre extérieur côté long 2 Marco exterior del lado largo 2	2	1
14		Deck Frame Connector Connecteur de cadre de plancher Conector del marco del piso	2	1

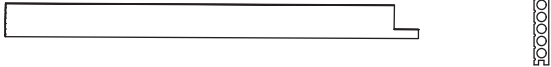
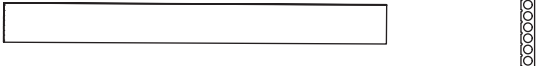



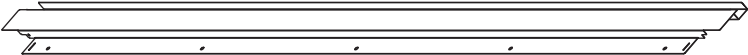

# Structure Parts List / Liste des pièces de la structure / Lista de piezas de la estructura

	PARTS LIST LISTE DES PIÈCES LISTA DE PIEZAS	DESCRIPTION DESCRIPTION DESCRIPCIÓN	QTY QTÉ CANT	CARTON# CARTON# CAJA#
15		Deck Frame Fastener Fixation du cadre de plancher Sujetador del marco del piso	2	1
16		Short Side Outer Frame Cadre extérieur côté court Marco exterior del lado corto	2	1
17		Support Tube 1 Tube de support 1 Tubo de soporte 1	4	1
18		Support Tube 2 Tube de support 2 Tubo de soporte 2	4	2
19		Middle Support Tube 1 Tube de support central 1 Tubo de soporte central 1	1	2
20		Middle Support Tube 2 Tube de support central 2 Tubo de soporte central 2	1	2
21		Leveling Foot Pied de nivellement Pata niveladora	40+2	2
22		Deck Clips Clips de plancher Clips para piso	84+4	1
23	 	Right Irregular Deck Plancher irrégulier droit Panel de piso irregular derecho	2	1





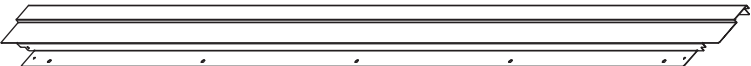

# *Structure Parts List / Liste des pièces de la structure / Lista de piezas de la estructura*



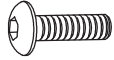

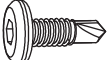
	PARTS LIST LISTE DES PIÈCES LISTA DE PIEZAS	DESCRIPTION DESCRIPTION DESCRIPCIÓN	QTY QTÉ CANT	CARTON# CARTON# CAJA#
24		Left Irregular Deck Plancher irrégulier gauche Panel de piso irregular izquierdo	2	1
25		Regular Deck Plancher standard Panel de piso regular	44	1
26		Short Side Cover Plate Plaque de couverture côté court Placa de cubierta lado corto	2	1
27		Middle Cover Plate Plaque de couverture centrale Placa de cubierta central	2	2
29		Long Side Cover Plate Plaque de couverture côté long Placa de cubierta lado largo	4	2
30		Gutter Connector Connecteur de gouttière Conector de canalón	2	2
31		Front Cover Couvercle avant Cubierta frontal	1	2
32		Turbine Turbine Turbina	1	1
33		Handle Manivelle Asa	1	1

## *Structure Parts List / Liste des pièces de la structure / Lista de piezas de la estructura*

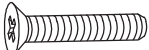
	PARTS LIST LISTE DES PIÈCES LISTA DE PIEZAS	DESCRIPTION DESCRIPTION DESCRIPCIÓN	QTY QTÉ CANT	CARTON# CARTON# CAJA#
34		Louver Persiennes Panel de rejillas	24	1
35		Left Louver Connector Connecteur de persienne (gauche) Conector rejilla izquierda	24+1	1
36		Right Louver Connector Connecteur de persienne (droite) Conector rejilla derecha	24+1	1
37		Fastening Piece Attache Pieza de fijación	48+2	2
38		Back Cover Couvercle arrière Cubierta trasera	1	2
39		Handle Storage Poignée de rangement Almacenamiento del asa	1	1
40		Handle Bracket Insertion de la manivelle Soporte del asa	1	1

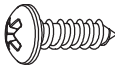
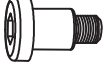
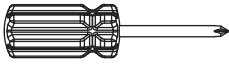
# Structure Parts List / Liste des pièces de la structure / Lista de piezas de la estructura

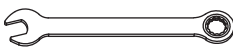
	PARTS LIST LISTE DES PIÈCES LISTA DE PIEZAS	DESCRIPTION DESCRIPTION DESCRIPCIÓN	QTY QTÉ CANT	CARTON# CARTON# CAJA#
A		M6x15 Bolt Boulon M6x15 Perno M6x15	75+4	1
B		M6x12 Bolt Boulon M6x12 Perno M6x12	2	1
C		Nut Écrou Tuerca	16+4	1
D		M5x15 Bolt Boulon M5x15 Perno M5x15	19+1	1
E		Anchor Ancrage Anclaje	6	1
F		ST4.2x50 Bolt Boulon ST4.2x50 Perno ST4.2x50	84+4	1
G		ST4x40 Bolt Boulon ST4x40 Perno ST4x40	8	1
H		M5x18 Bolt Boulon M5x18 Perno M5x18	1	1

	PARTS LIST LISTE DES PIÈCES LISTA DE PIEZAS	DESCRIPTION DESCRIPTION DESCRIPCIÓN	QTY QTÉ CANT	CARTON# CARTON# CAJA#
J		ST4.8x10 Bolt Boulon ST4.8x10 Perno ST4.8x10	48+2	1
K		Ø8.8x10xM6x5 Bolt Boulon Ø8.8x10xM6x5 Perno Ø8.8x10xM6x5	24+2	1
L		Phillips Screwdriver Tournevis à pointe cruciforme Destornillador Phillips	1	1
M		4mm Hex Wrench Clé hexagonale de 4 mm Llave hexagonal 4 mm	2	1
N		Wrench Clé Llave inglesa	1	1
P		Wrench Clé Llave inglesa	1	1
Q		M6x10 Bolt Boulon M6x10 Perno M6x10	8	1

# *Tools Required / Outils requis / Herramientas necesarias*

not included / non comprises / no incluidas

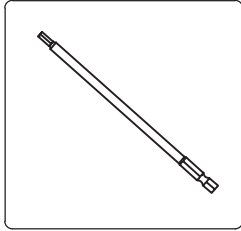

4mm Hex Socket Bit  
Embout hexagonal 4 mm  
Punta hexagonal de 4 mm

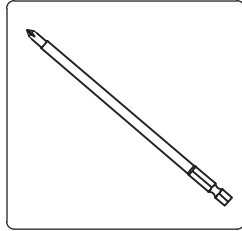

Cross Bit  
Embout cruciforme  
Punta de cruz

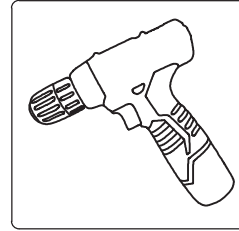

Cordless Drill  
Perceuse sans fil  
Taladro inalámbrico

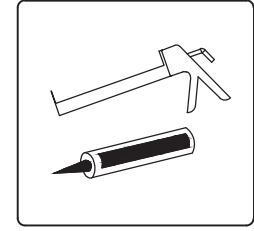

Silicone Sealant  
Mastic silicone  
Sellador de silicona

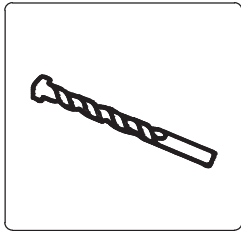

10mm Impact Drill Bit  
Mèche à percussion 10 mm  
Broca de impacto de 10 mm

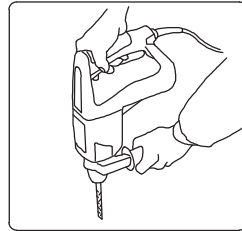

Hammer Drill  
Perceuse à percussion  
Taladro percutor

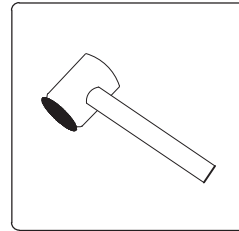

Hammer  
Marteau  
Martillo

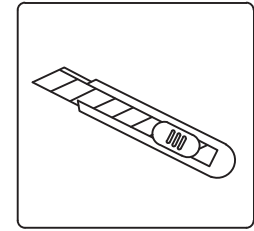

Cutter  
Cutter  
Cúter

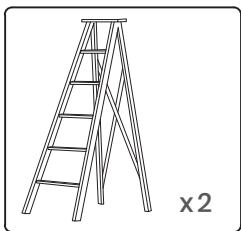

Ladder  
Échelle  
Escalera

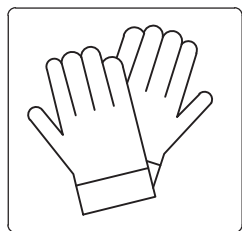

Glove  
Gant  
Guante

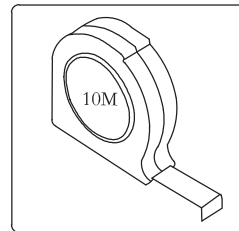

Tape Measure  
Mètre ruban  
Cinta métrica

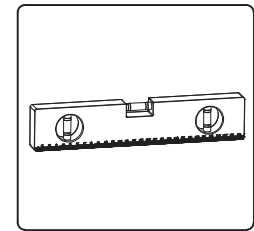

Leveler  
Niveau  
Nivel

*Structure Assembly / Montage de la structure / Ensamble de la estructura*

**1**

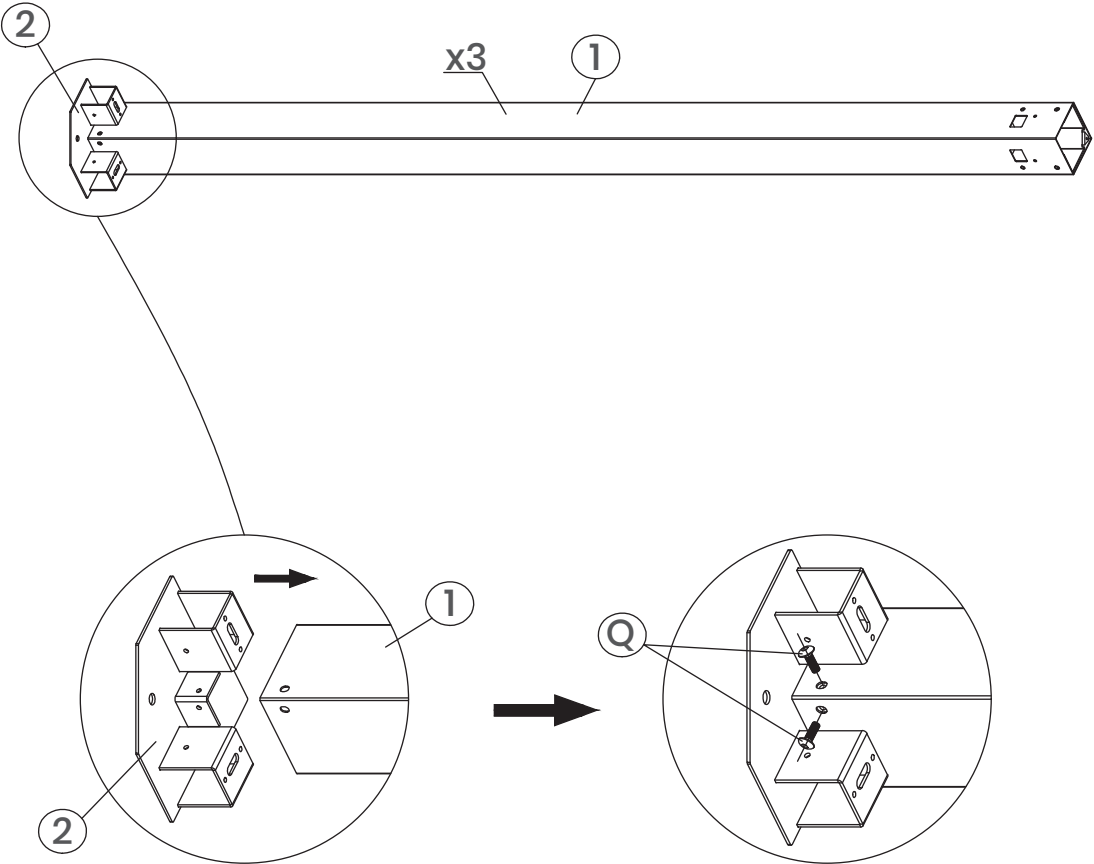

1 (X3)	2 (X3)	M6x10 (X6)

*Structure Assembly / Montage de la structure / Ensamble de la estructura*

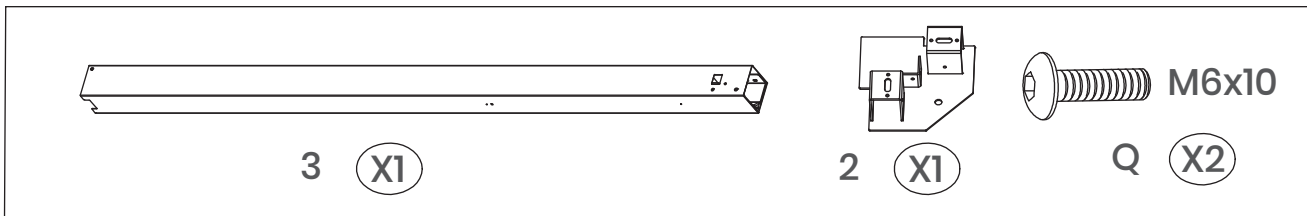
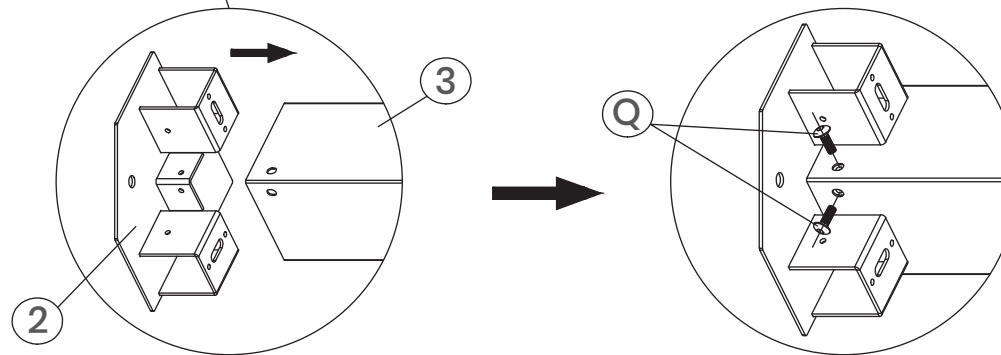
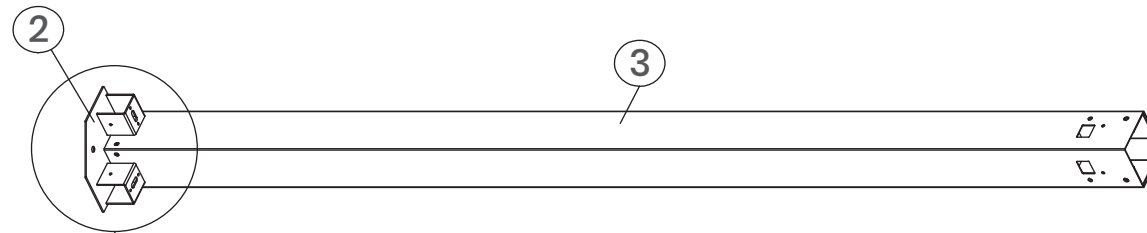

2

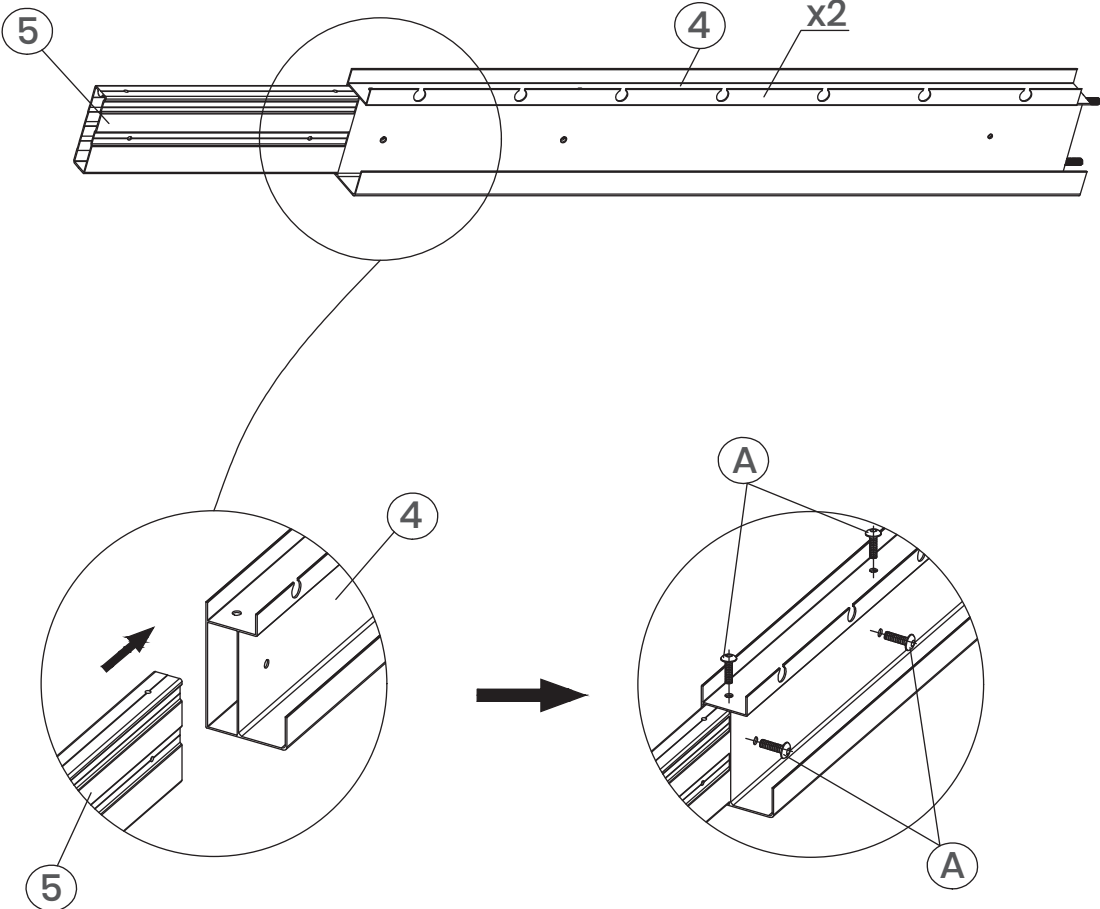

*Structure Assembly / Montage de la structure / Ensamble de la estructura*

3

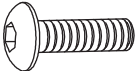

	4	X2		M6x15 A	X8
	5	X2			

*Structure Assembly / Montage de la structure / Ensamble de la estructura*

4

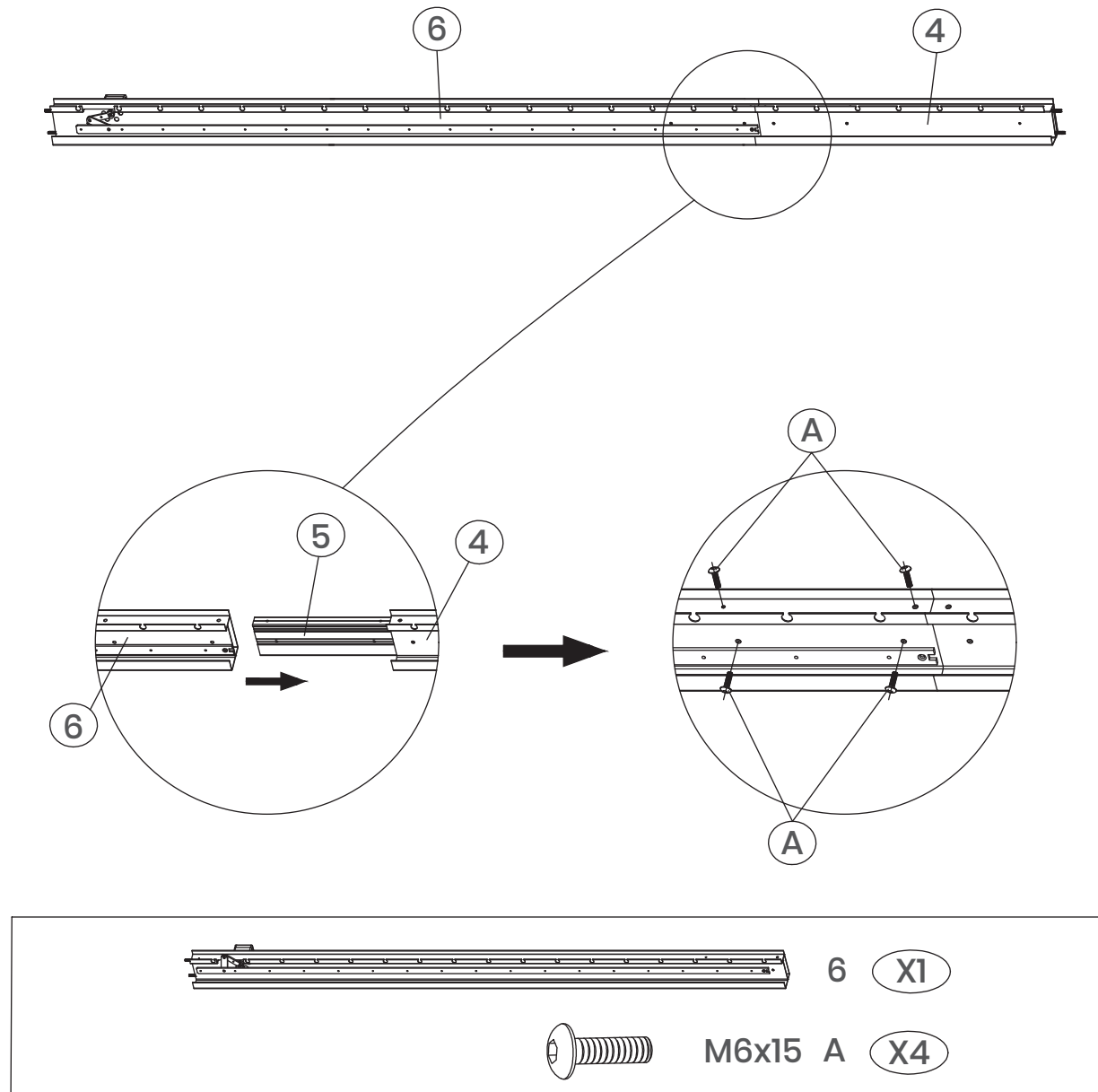

*Structure Assembly / Montage de la structure / Ensamble de la estructura*

5

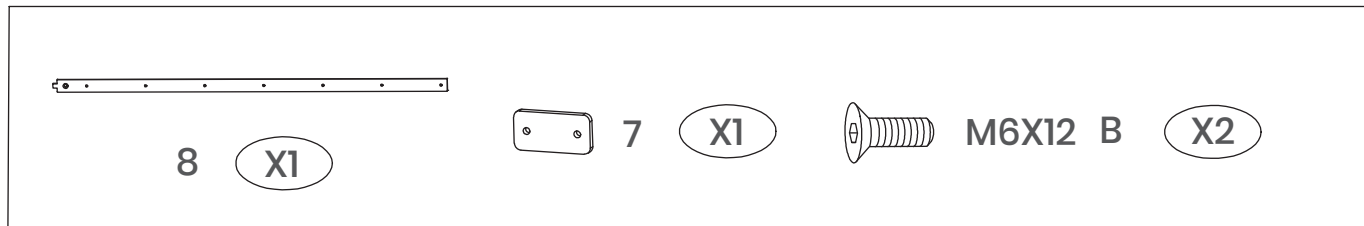
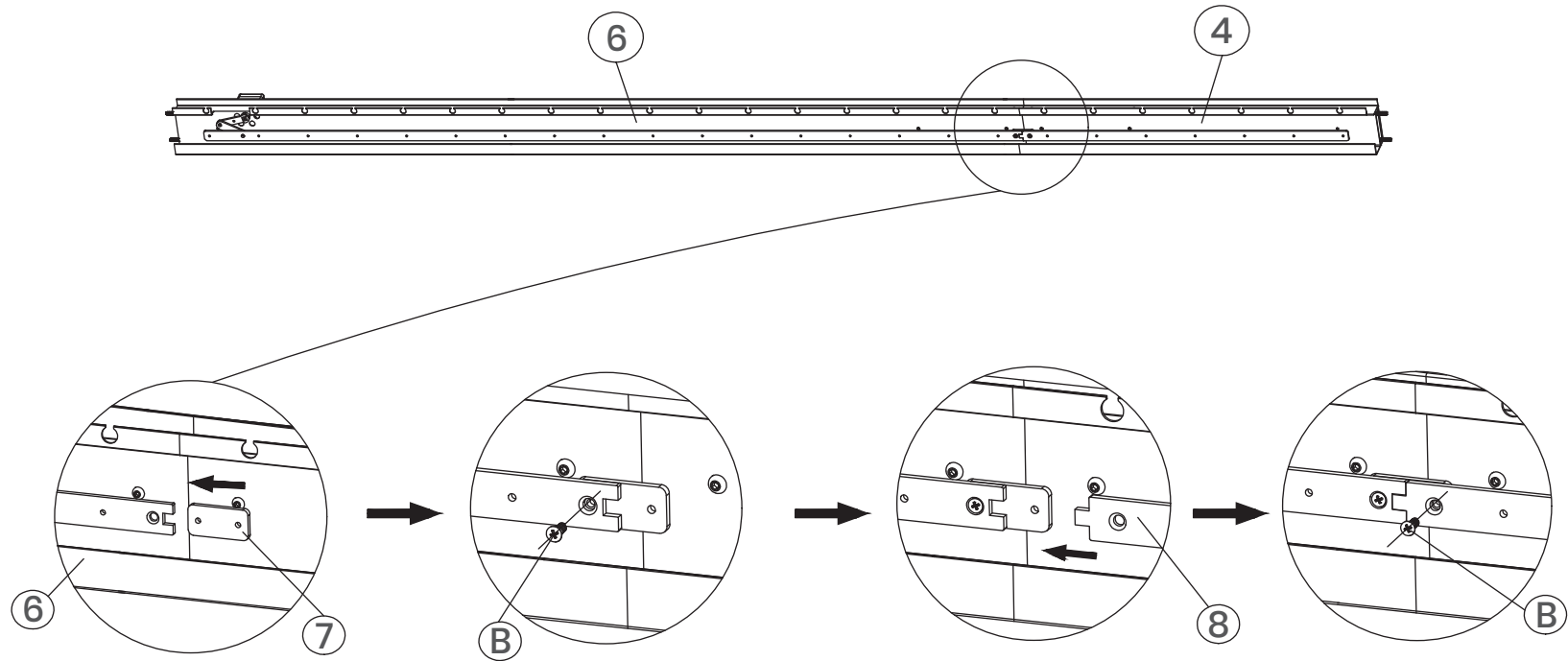

*Structure Assembly / Montage de la structure / Ensamble de la estructura*

6

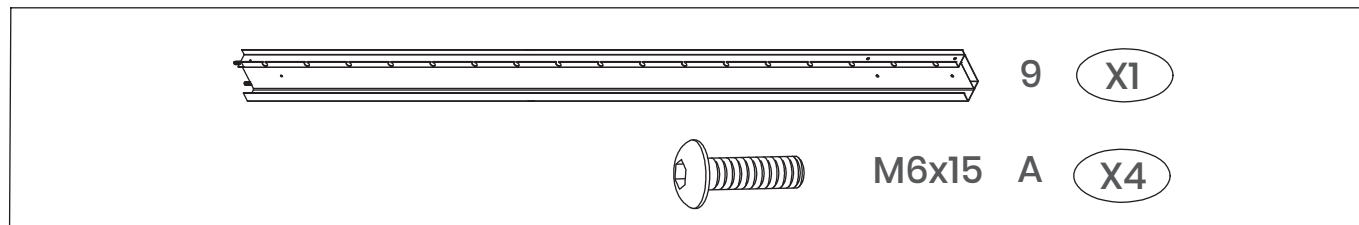
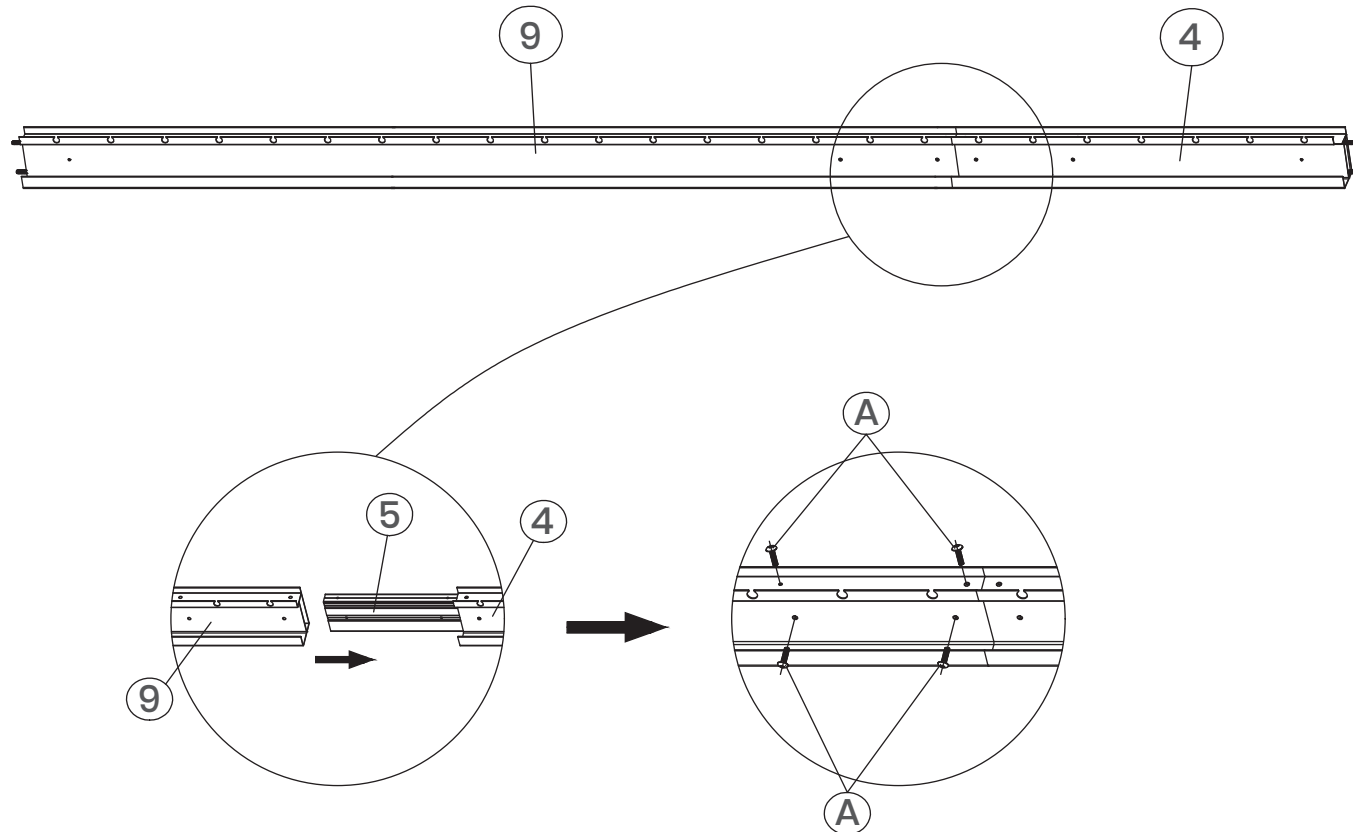

# Structure Assembly / Montage de la structure / Ensamble de la estructura

# 7

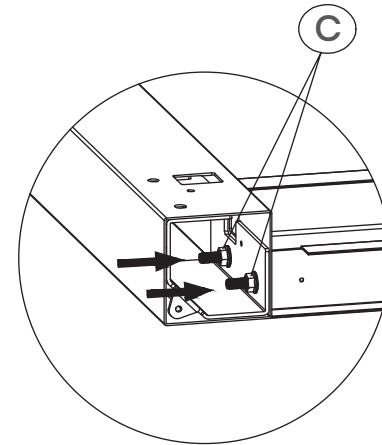
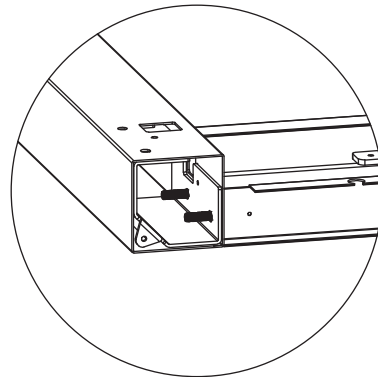
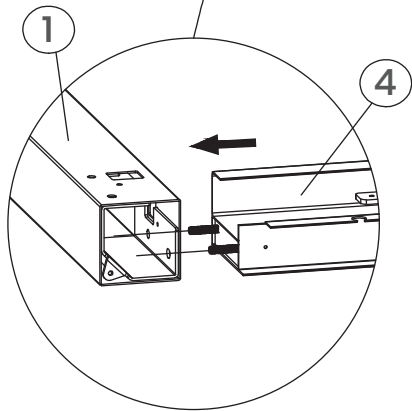
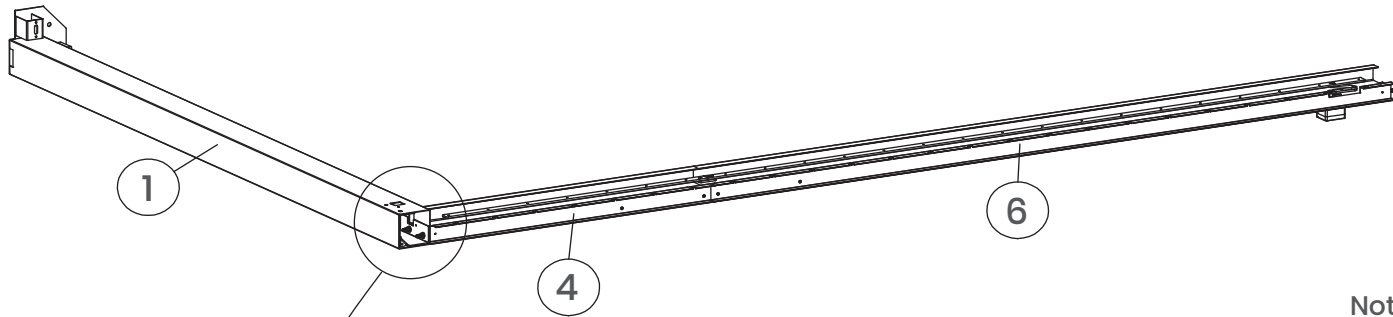

Note: Please tighten the screws.  
Remarque : Veuillez serrer les vis.  
Nota: Por favor, apriete los tornillos.

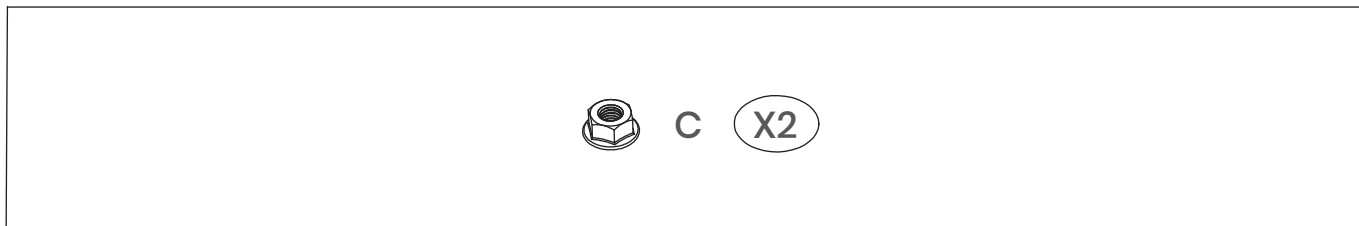

# Structure Assembly / Montage de la structure / Ensamble de la estructura

# 8

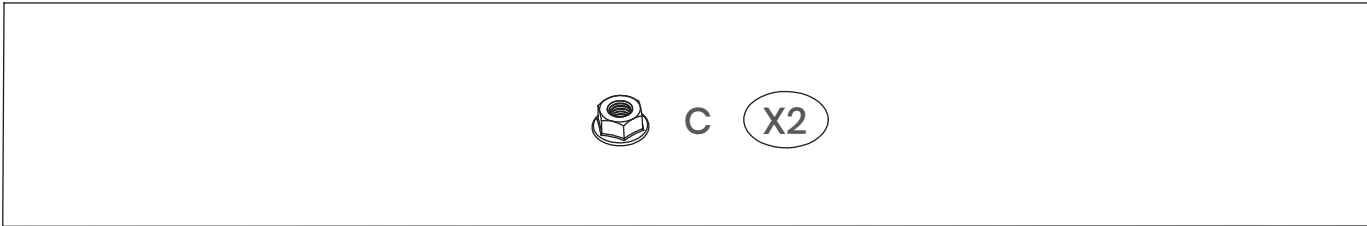
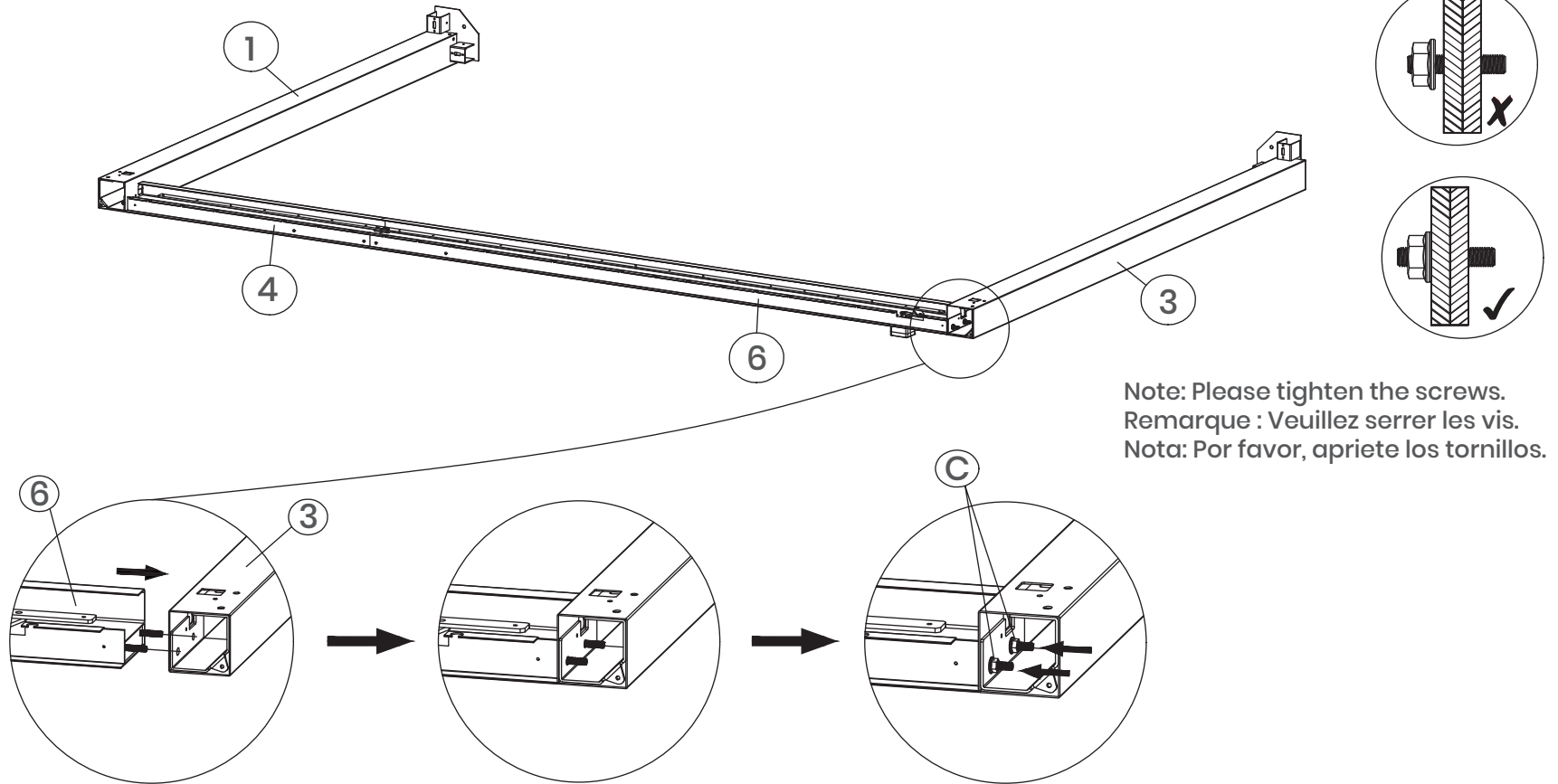

# Structure Assembly / Montage de la structure / Ensamble de la estructura

# 9

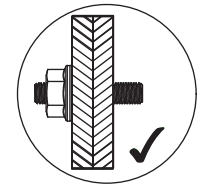
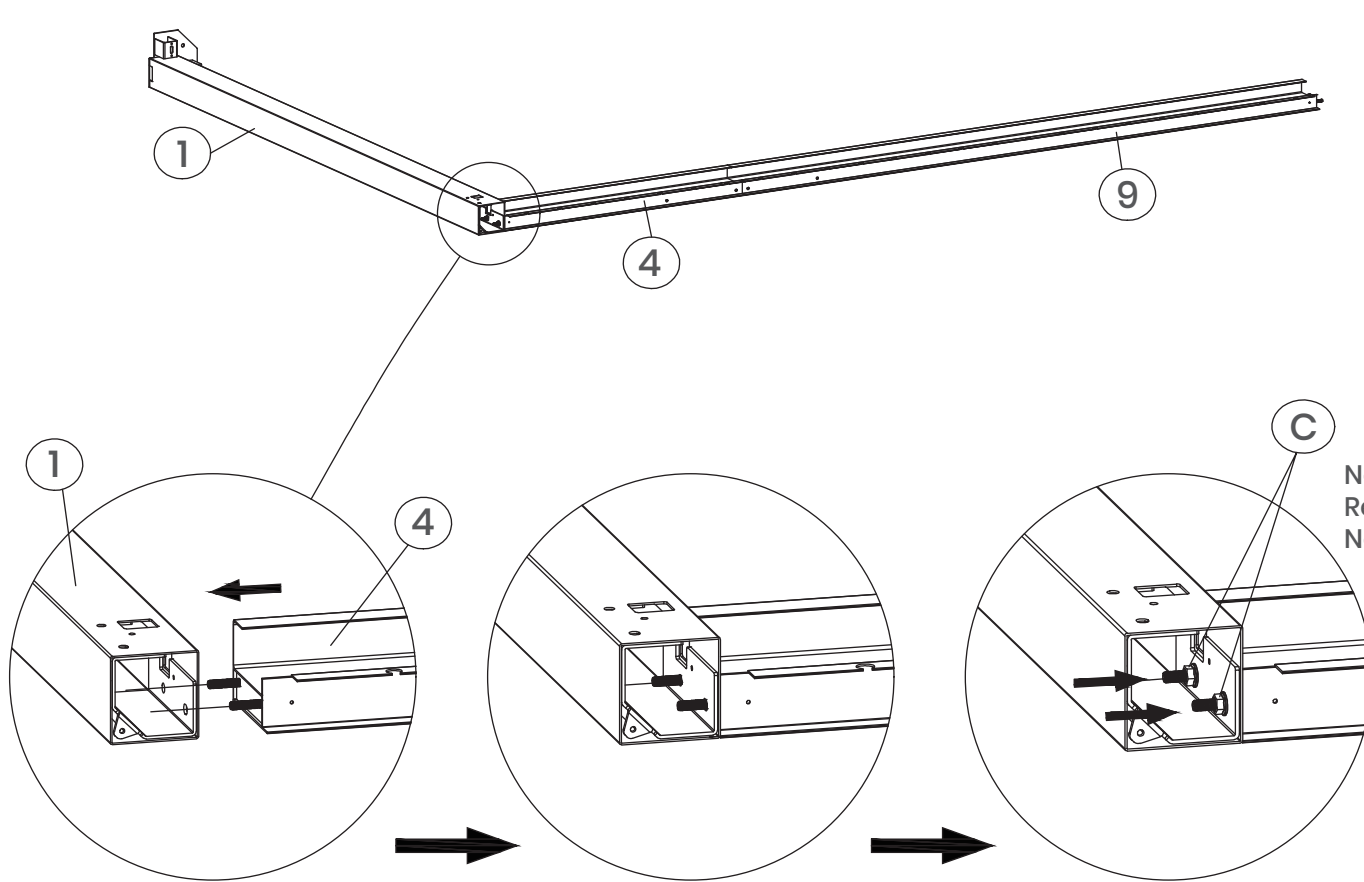

Note: Please tighten the screws.  
Remarque : Veuillez serrer les vis.  
Nota: Por favor, apriete los tornillos.

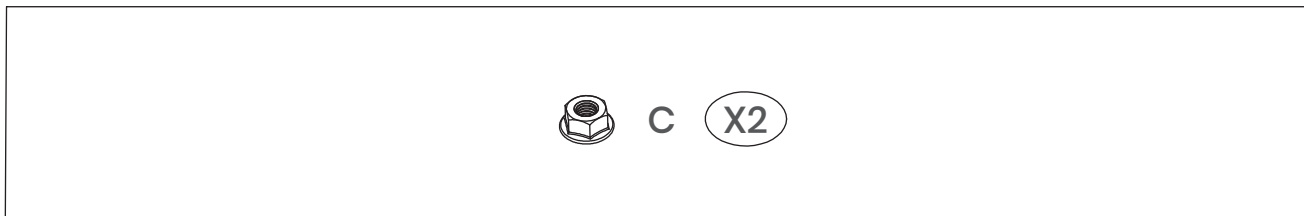

# Structure Assembly / Montage de la structure / Ensamble de la estructura

## 10

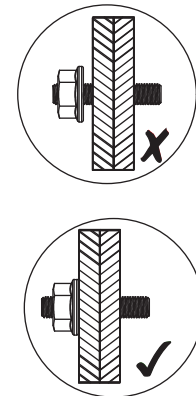
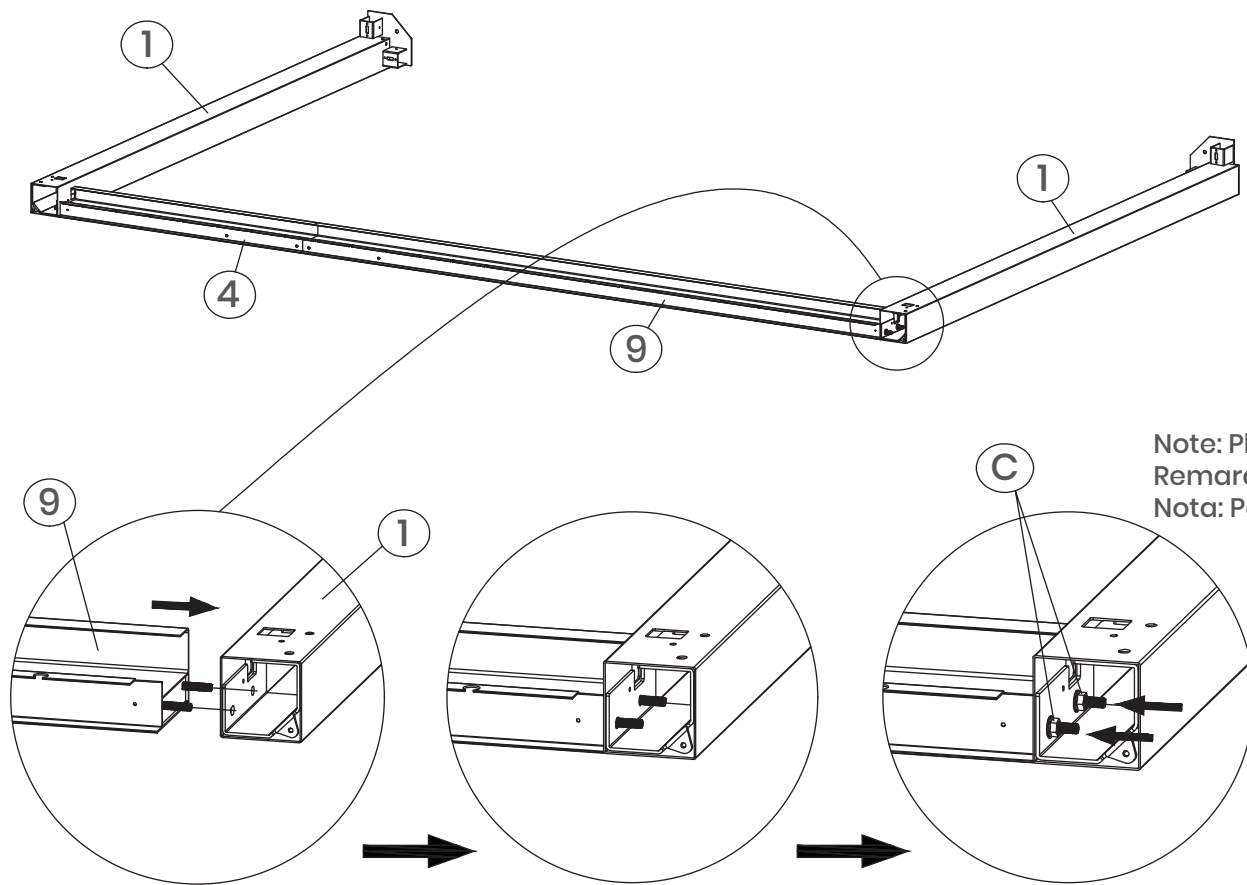

Note: Please tighten the screws.  
Remarque : Veuillez serrer les vis.  
Nota: Por favor, apriete los tornillos.

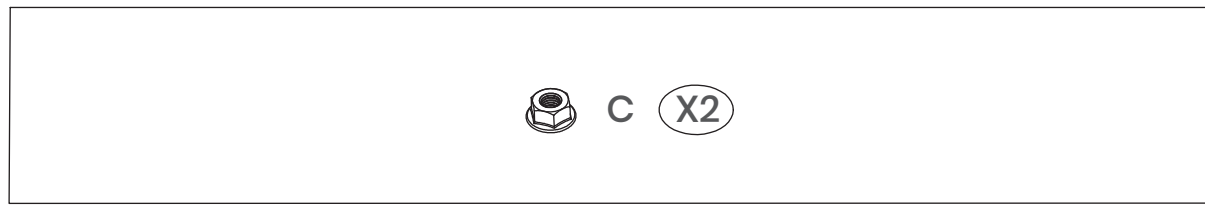

# 11

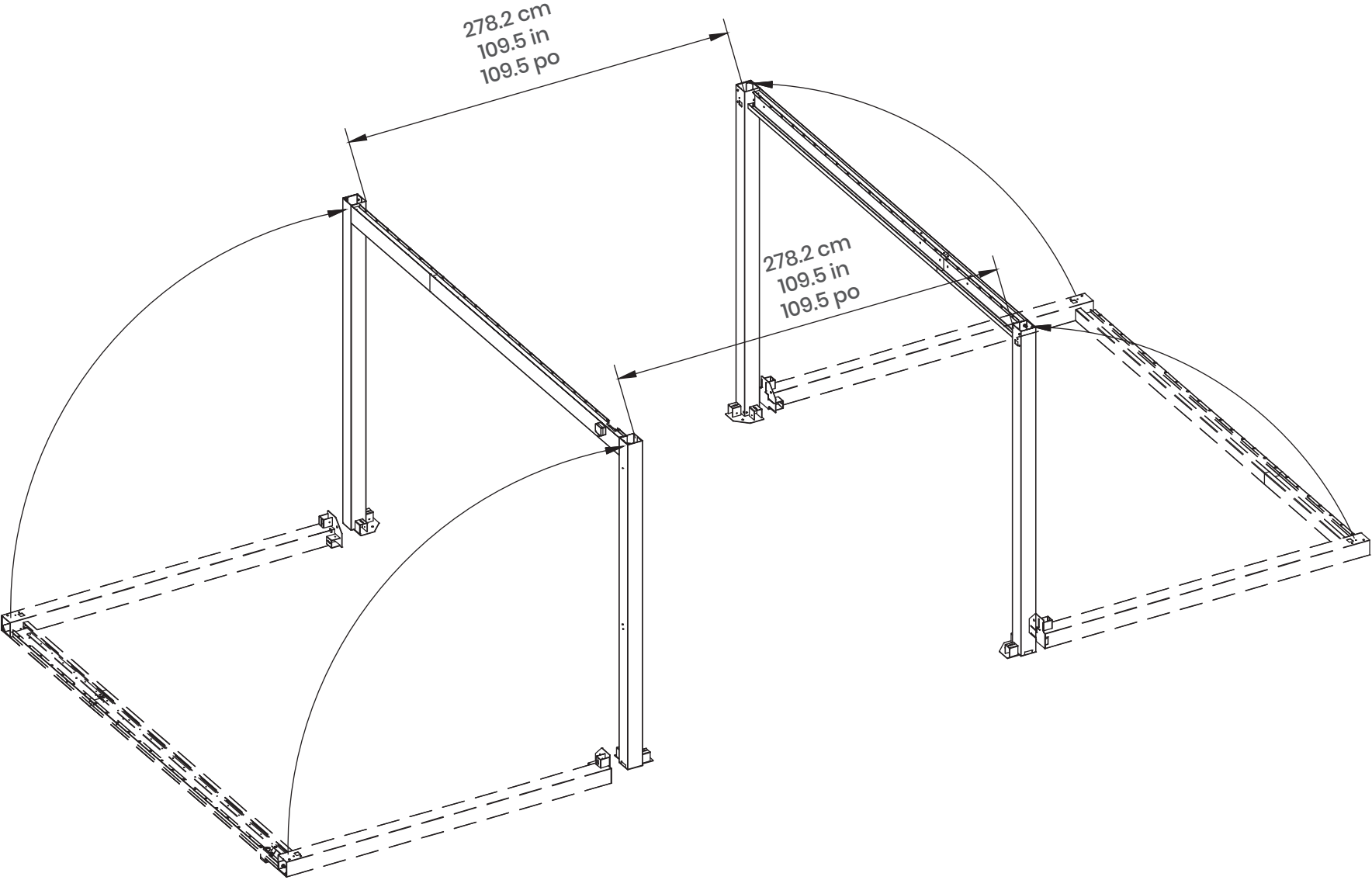

Structure Assembly / Montage de la structure / Ensamble de la estructura

# 12

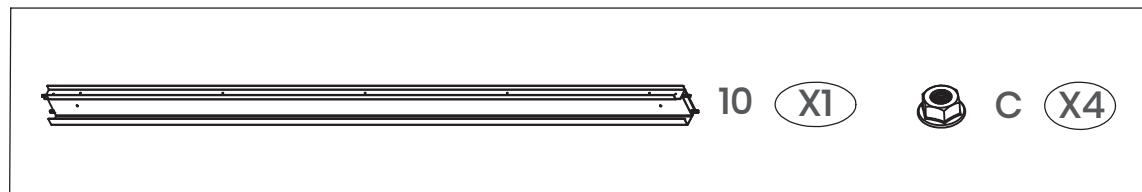
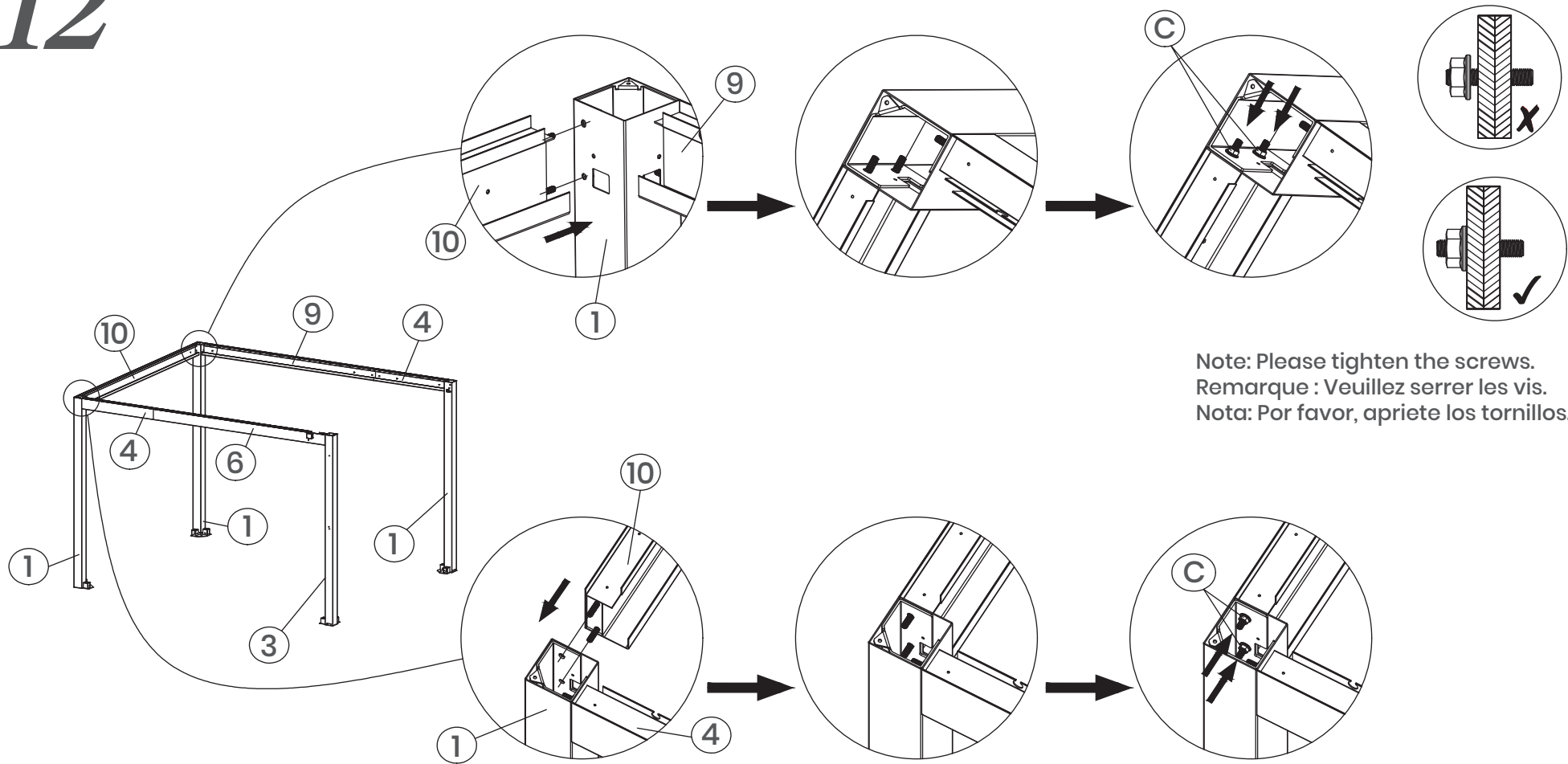

*Structure Assembly / Montage de la structure / Ensamble de la estructura*

13

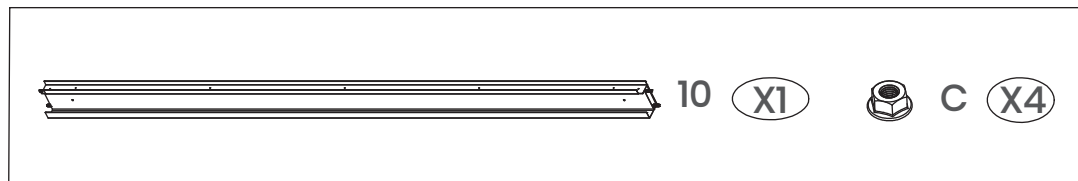
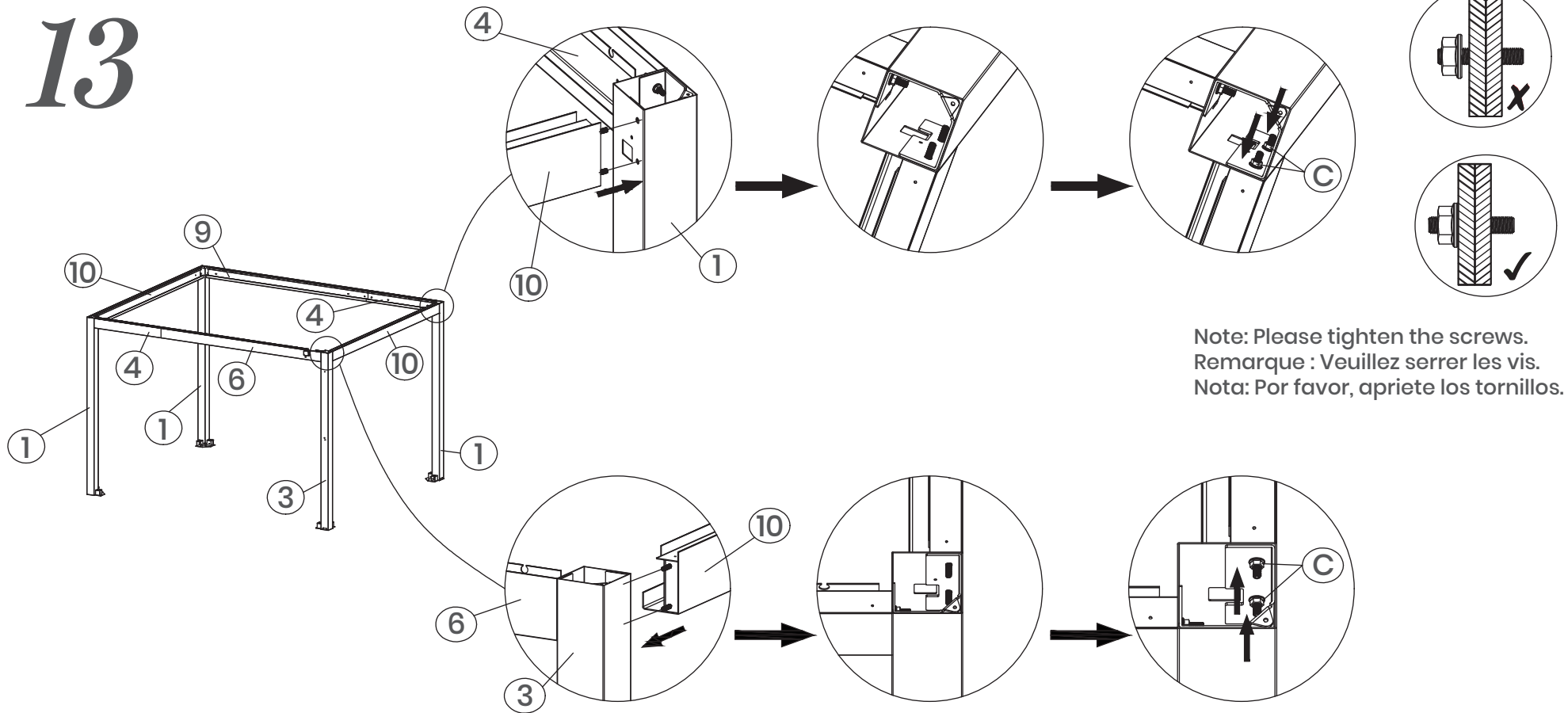

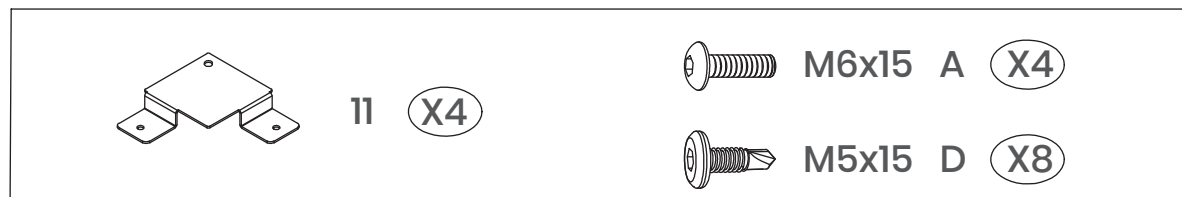
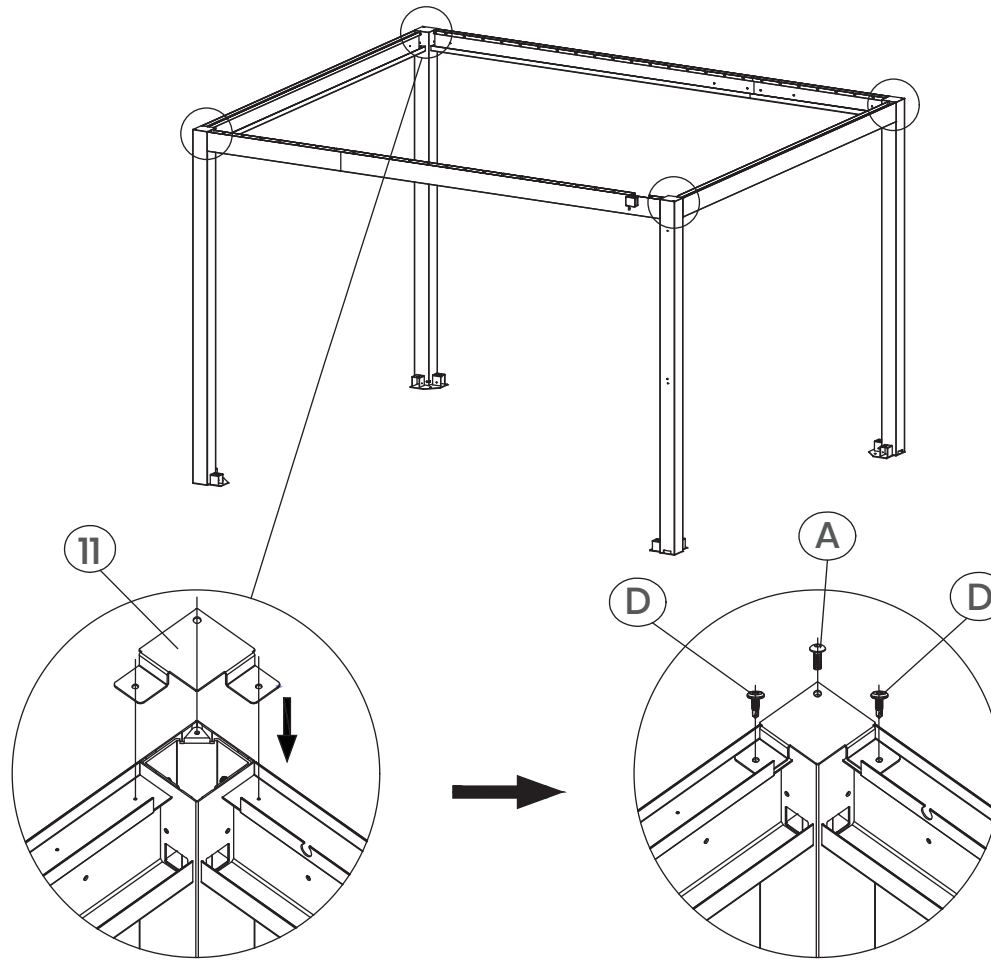

# 14

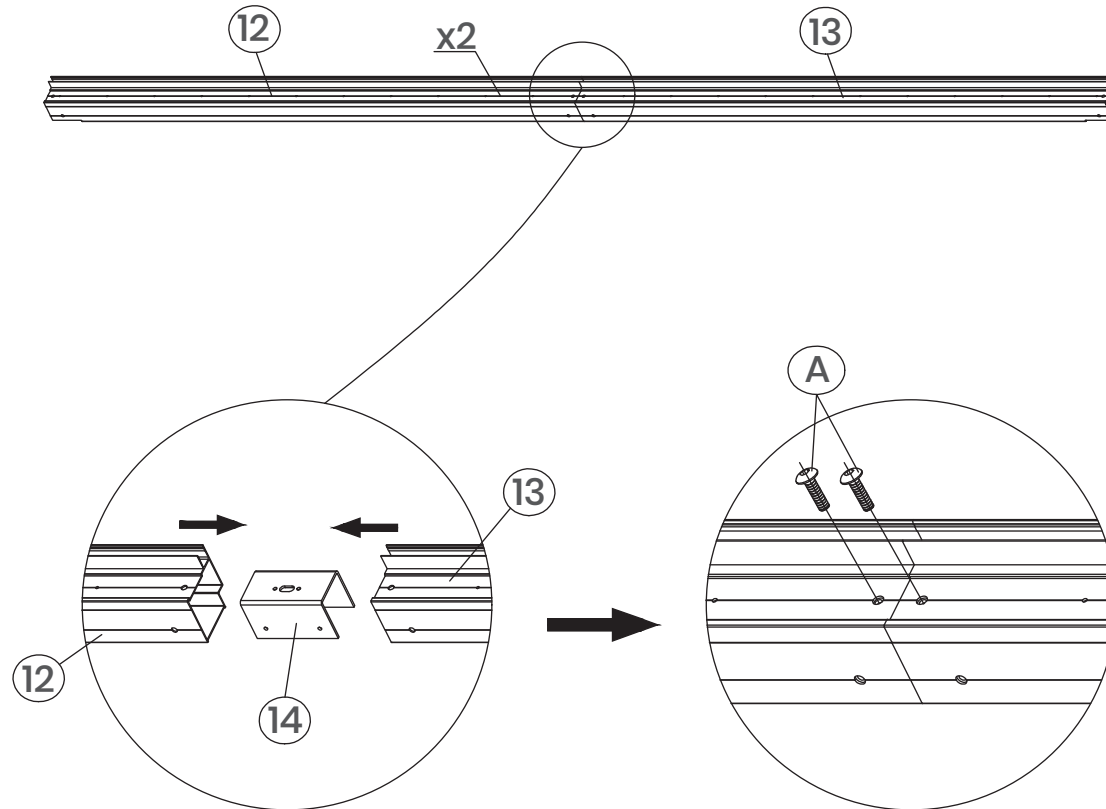

# 15

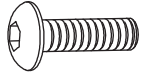

	12	X2		14	X2
	13	X2		M6x15 A	X4

# 16

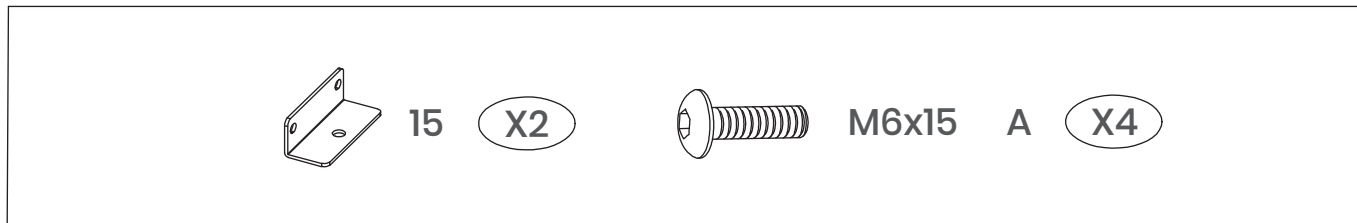
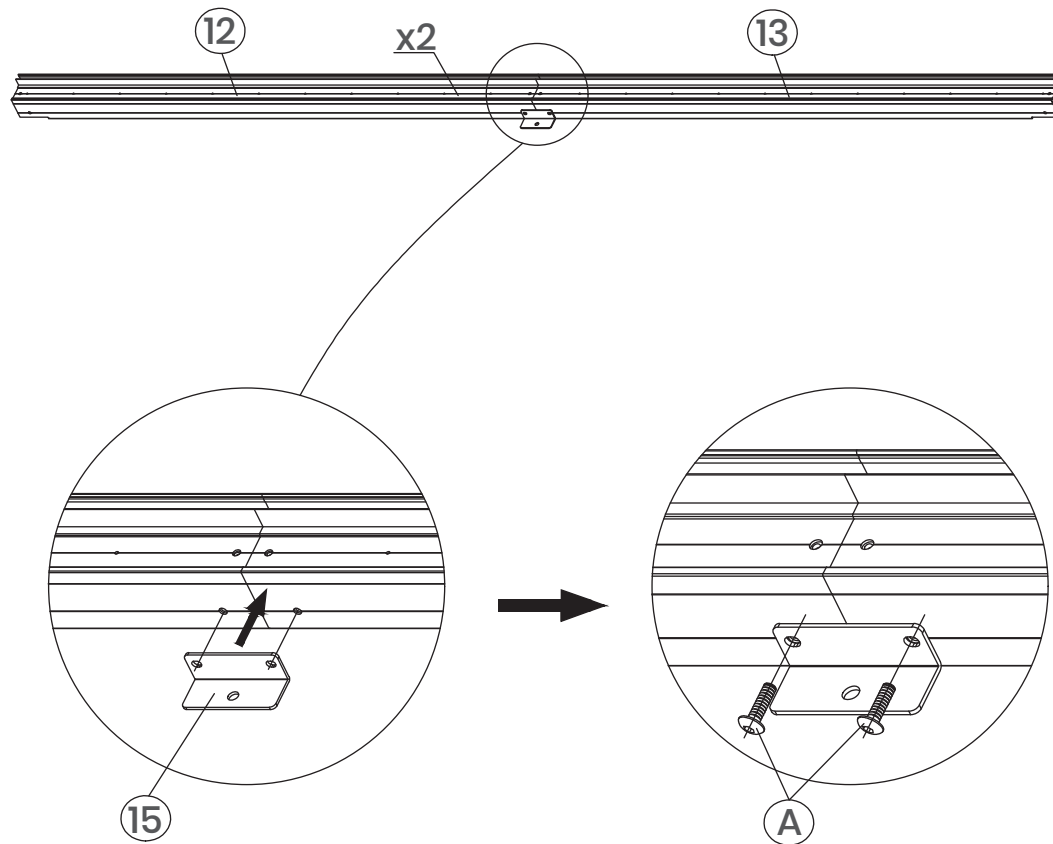

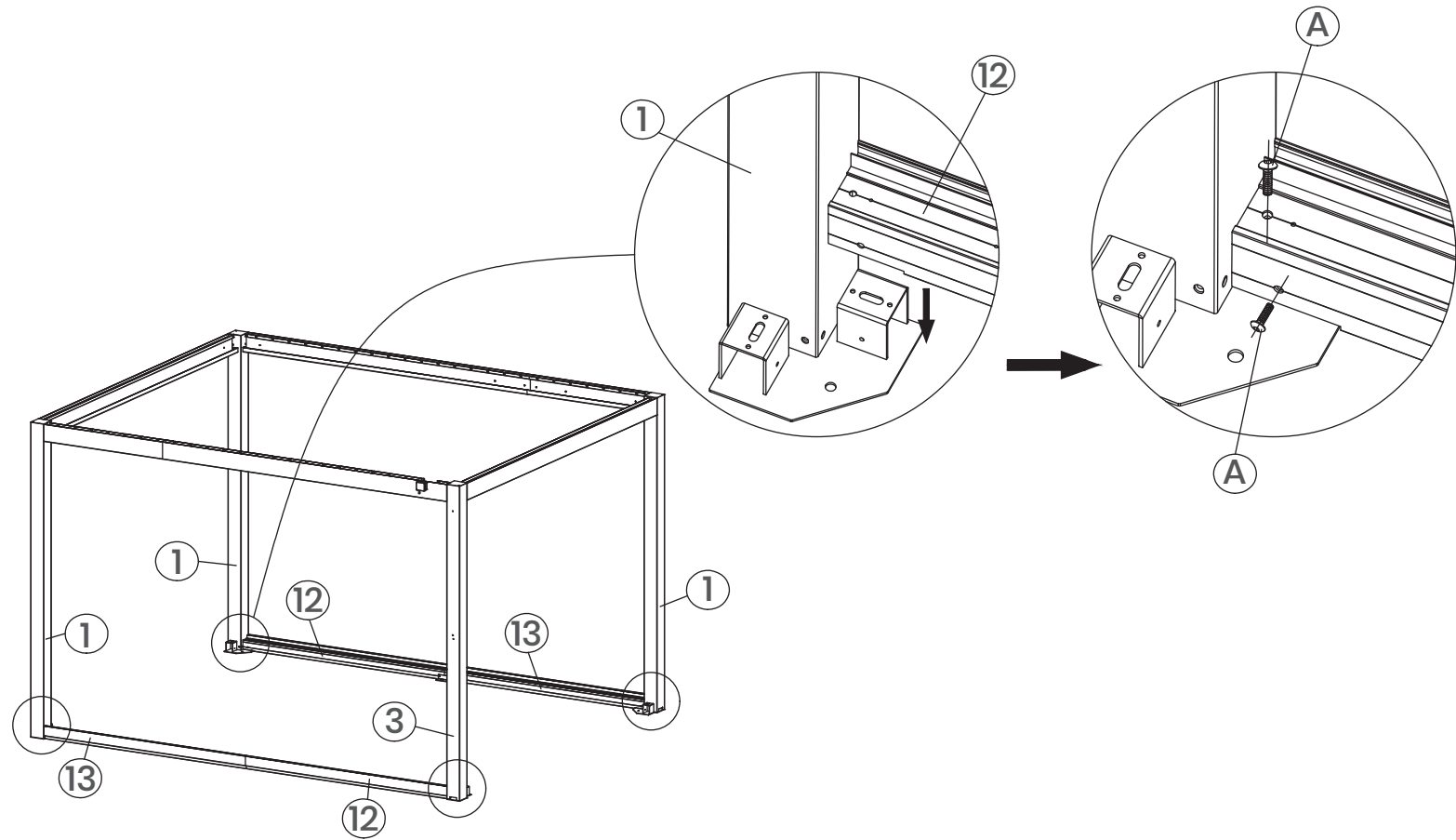

# 17

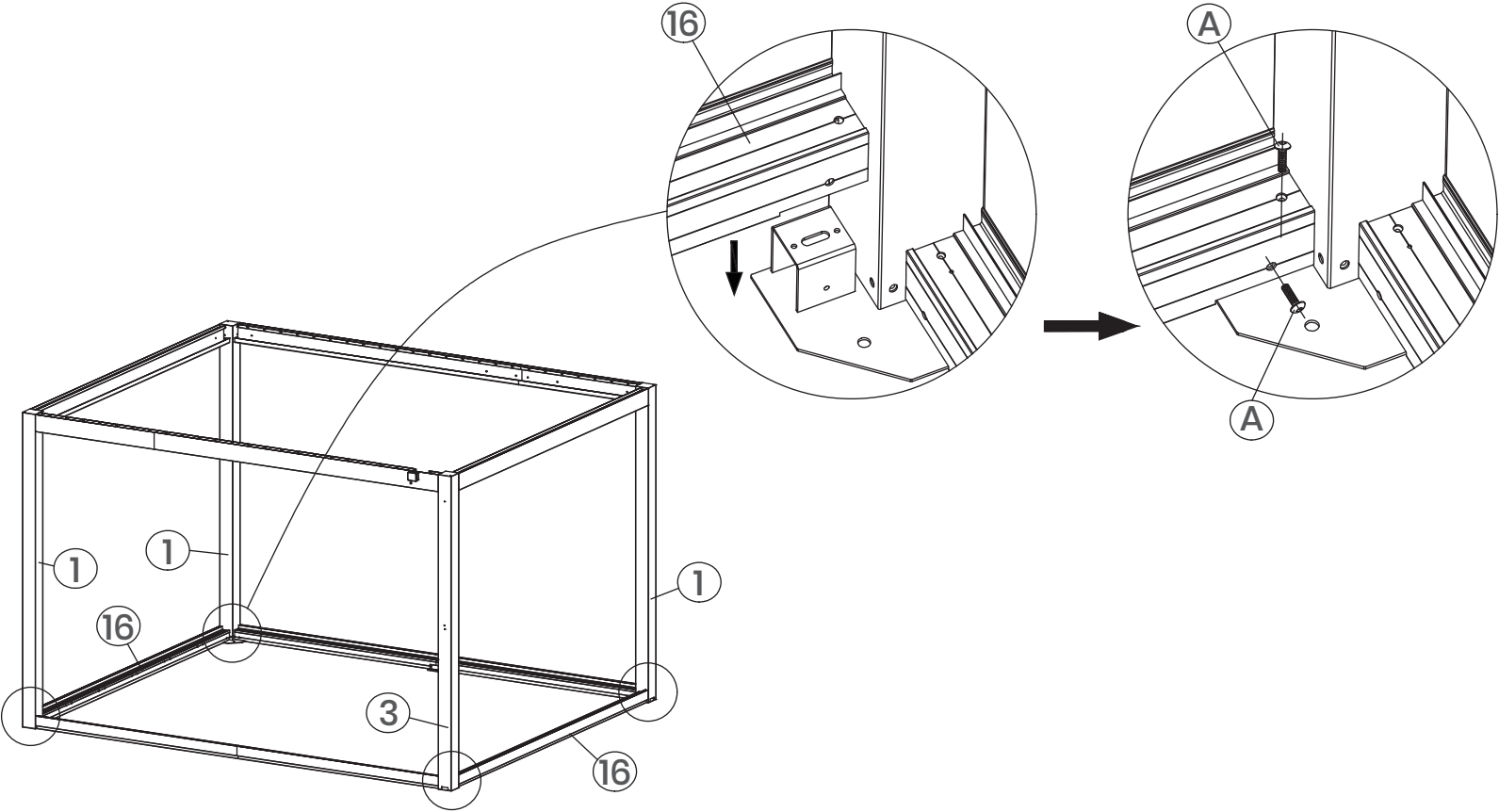

 M6x15 A (X8)

# 18

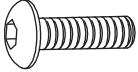

	M6x15	A	(X8)
	16		(X2)

# 19

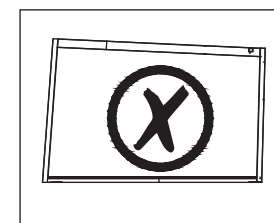
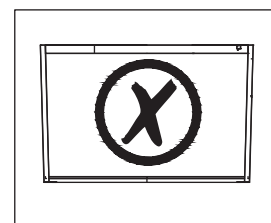
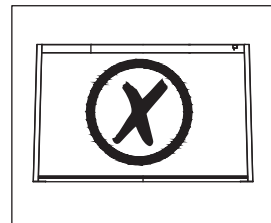
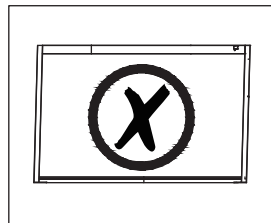
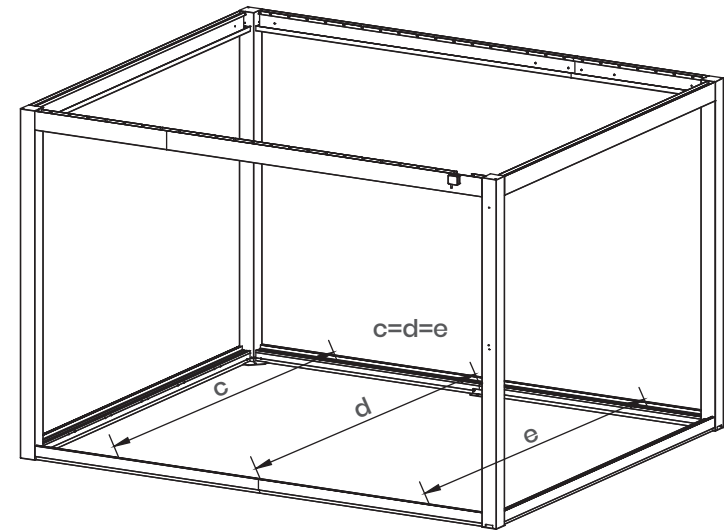
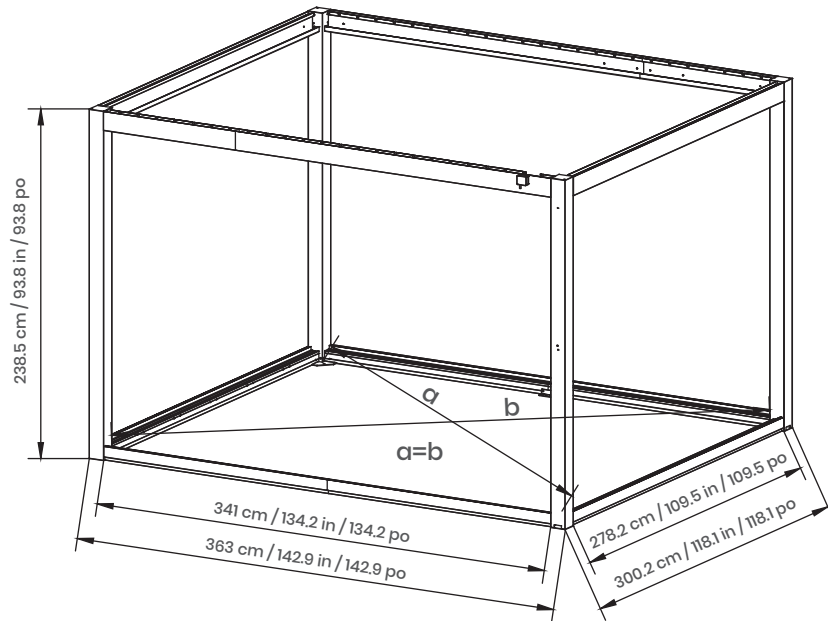

# 20

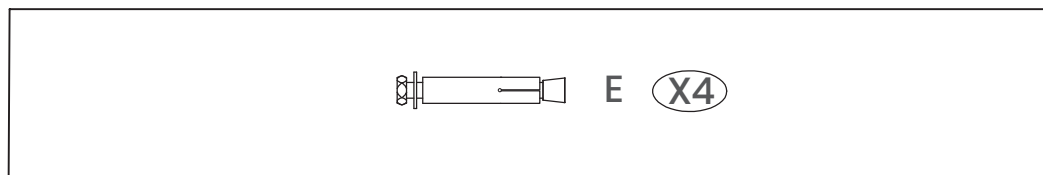
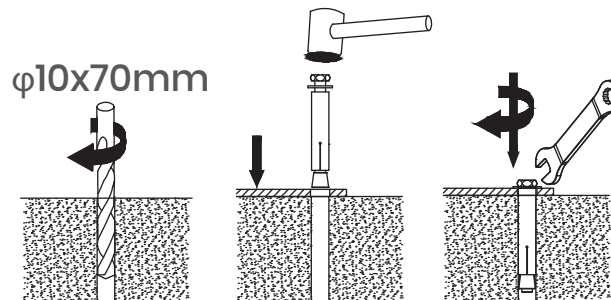
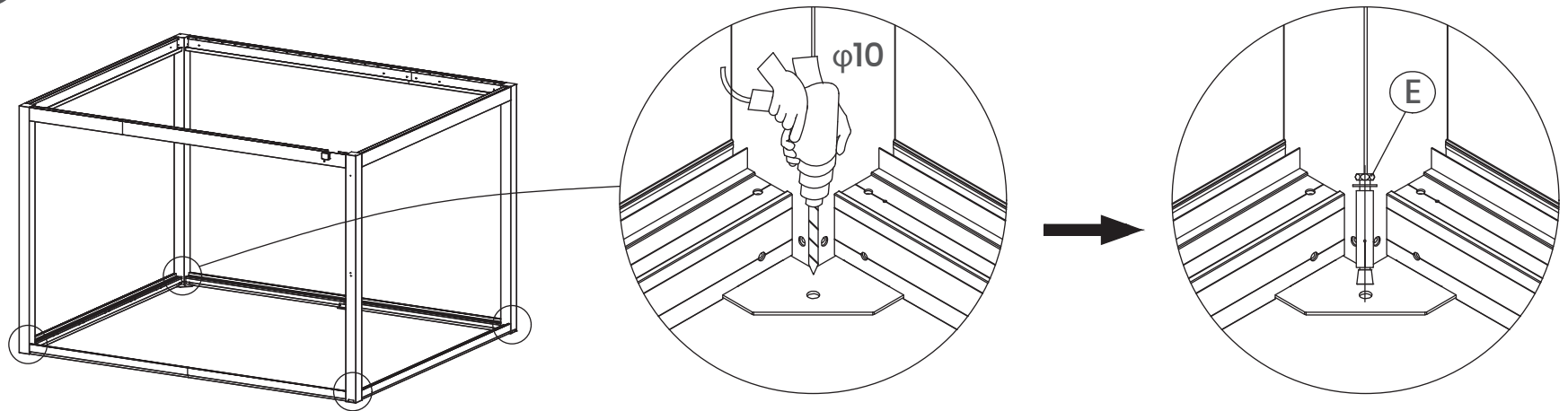

# 21

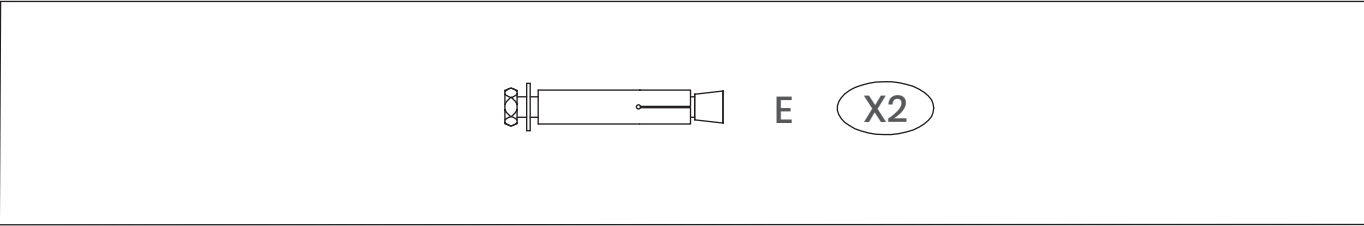
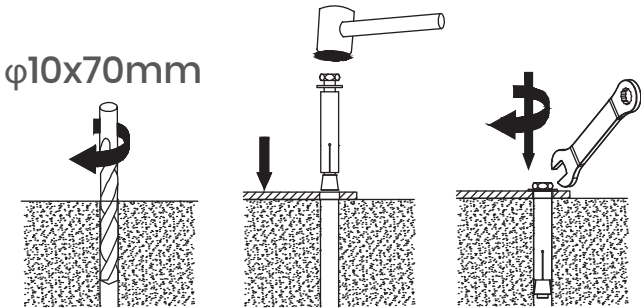
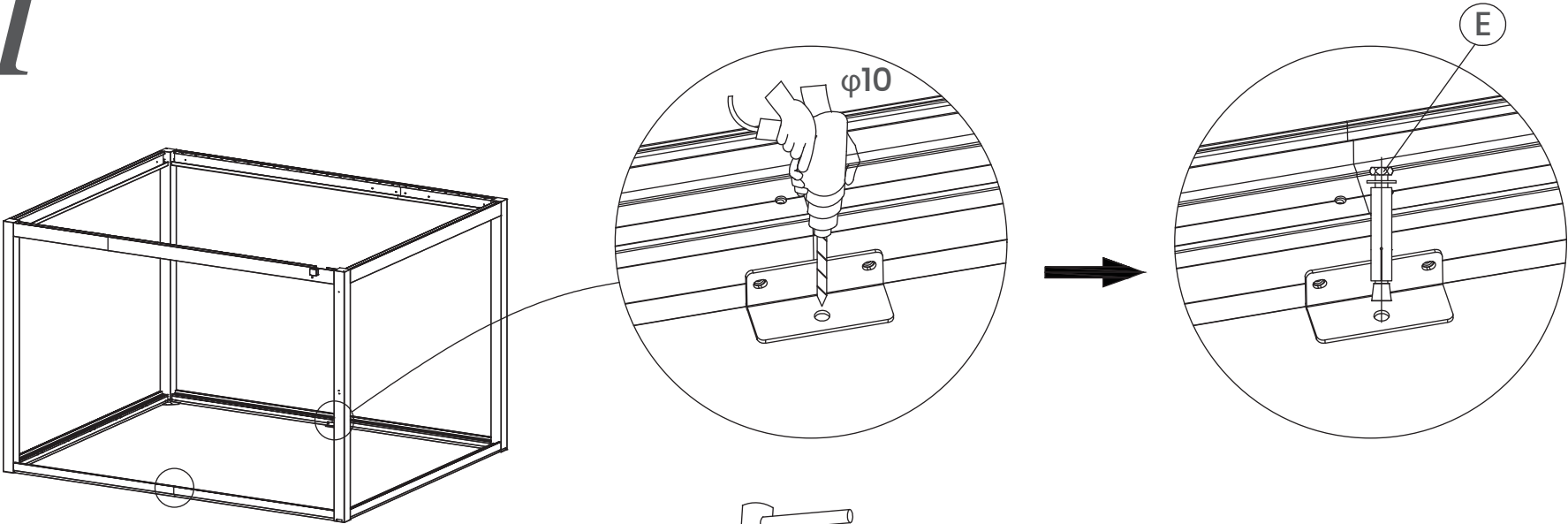

# 22

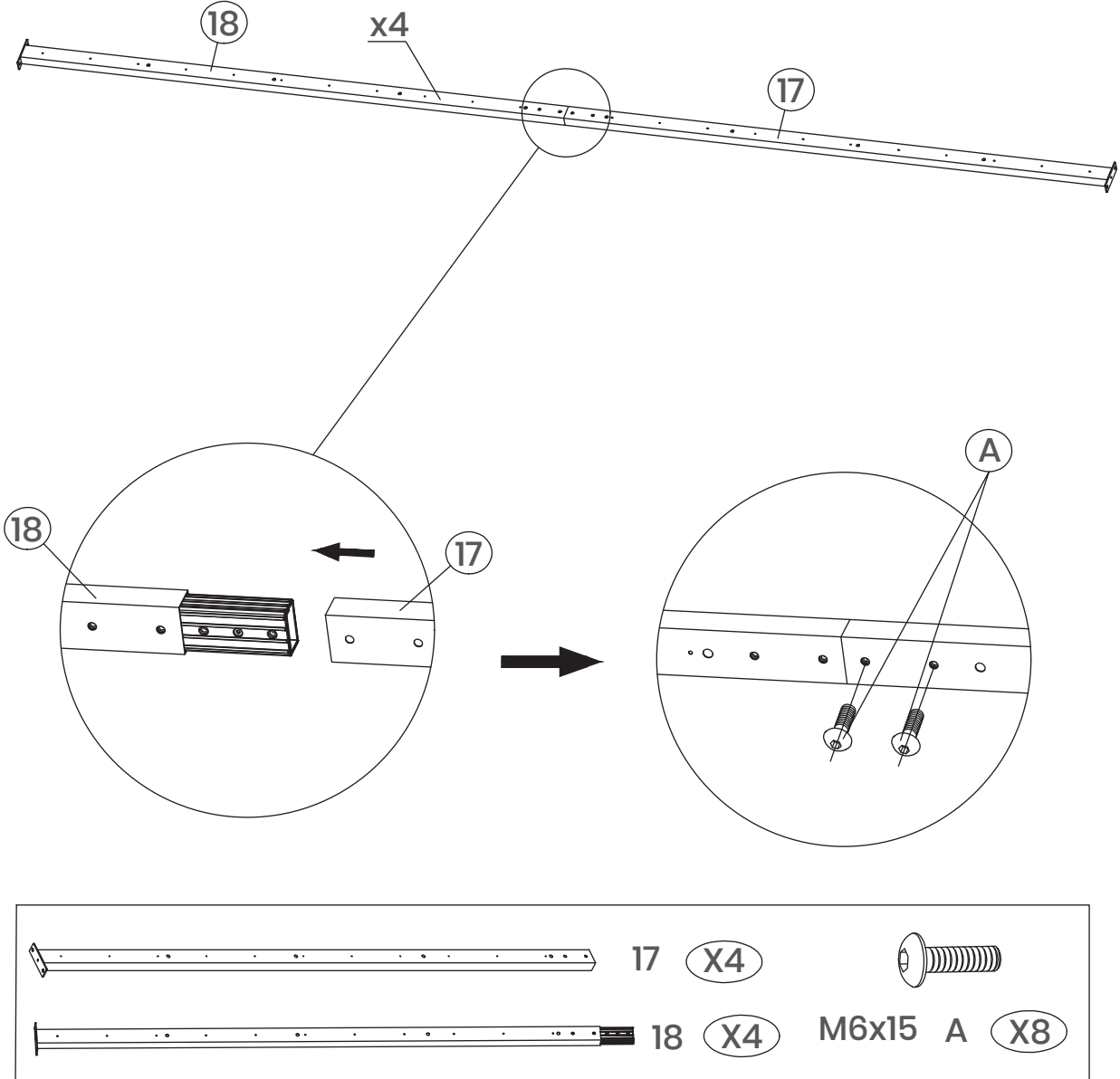

# 23

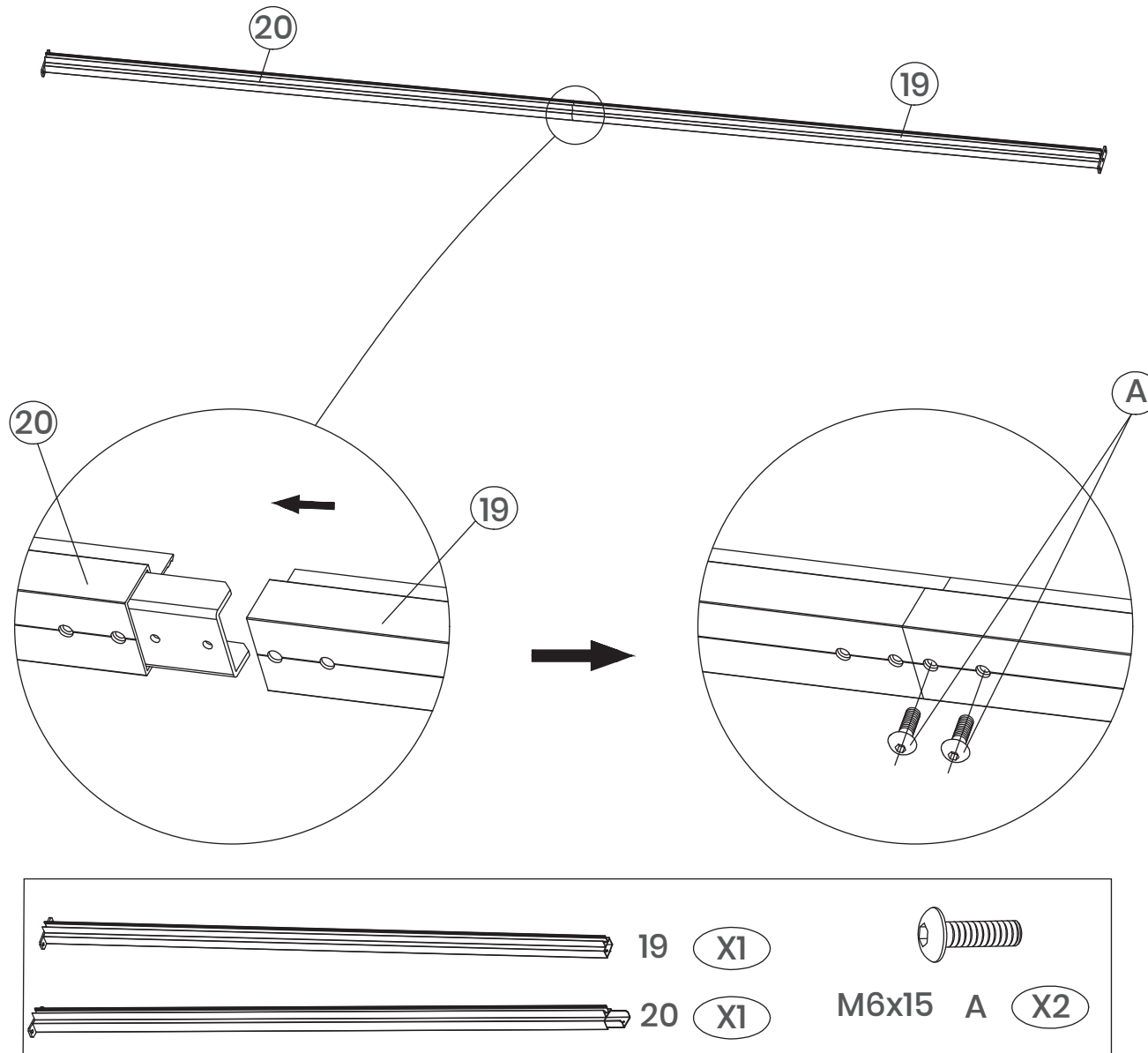

# 24

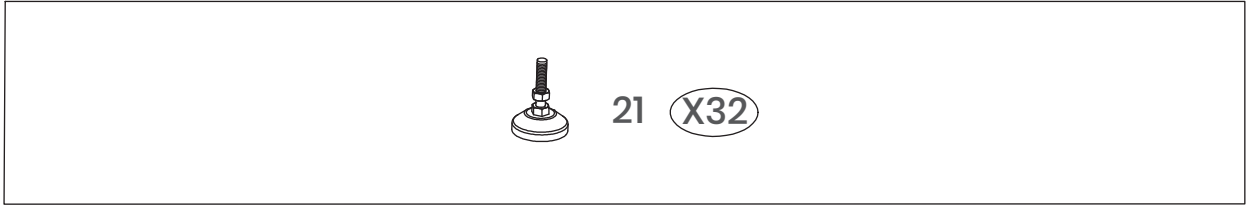
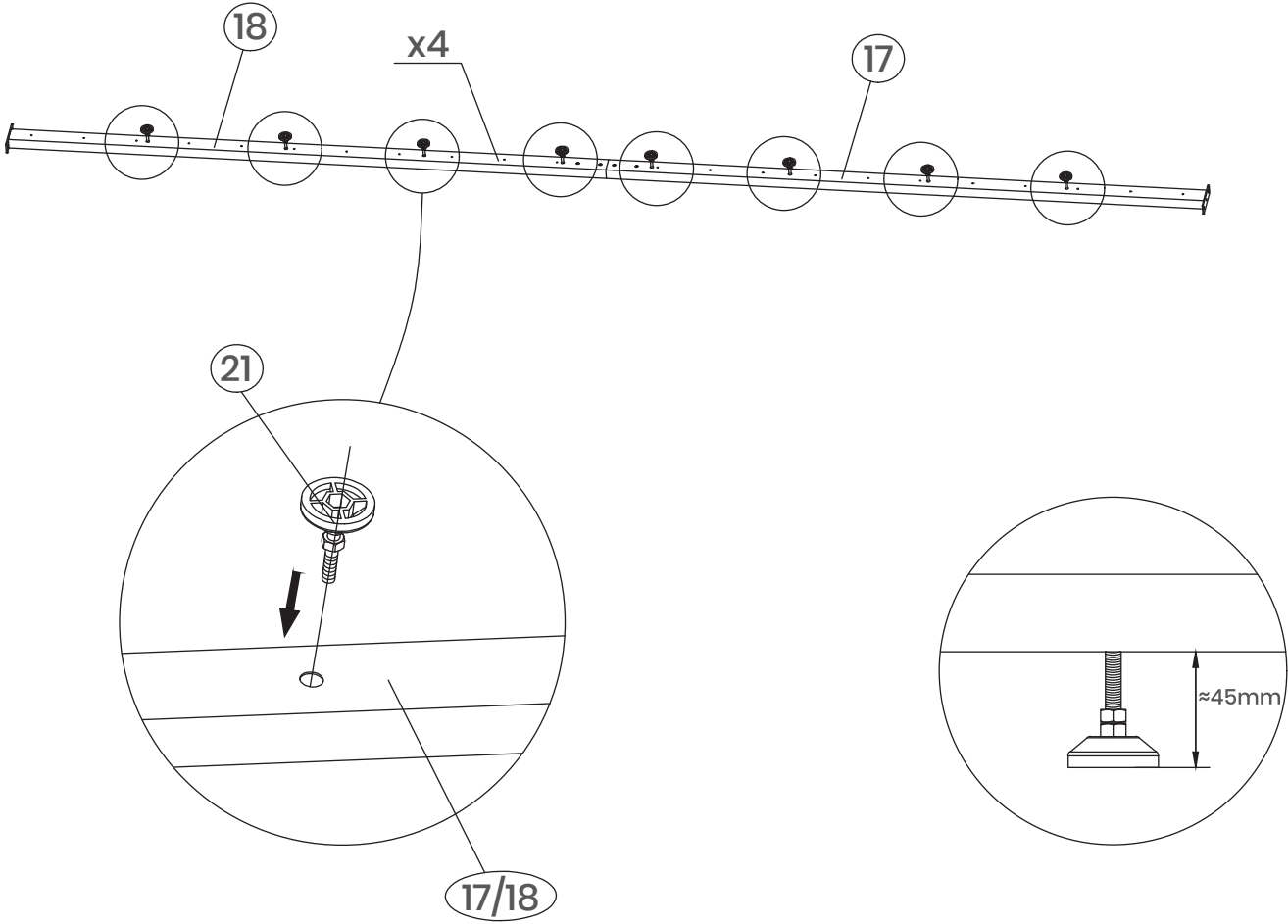

25

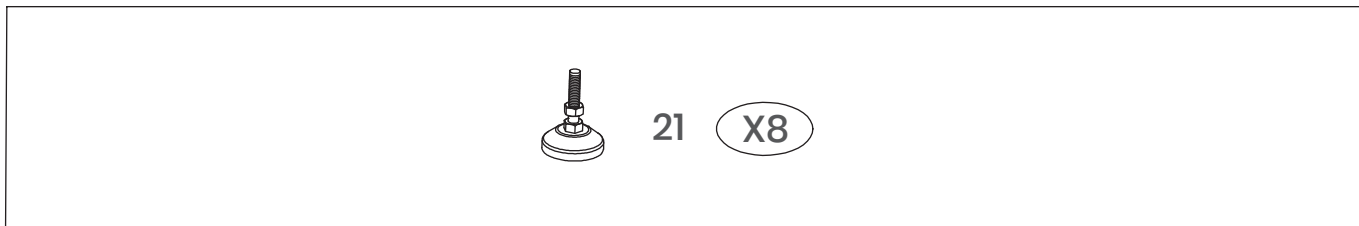
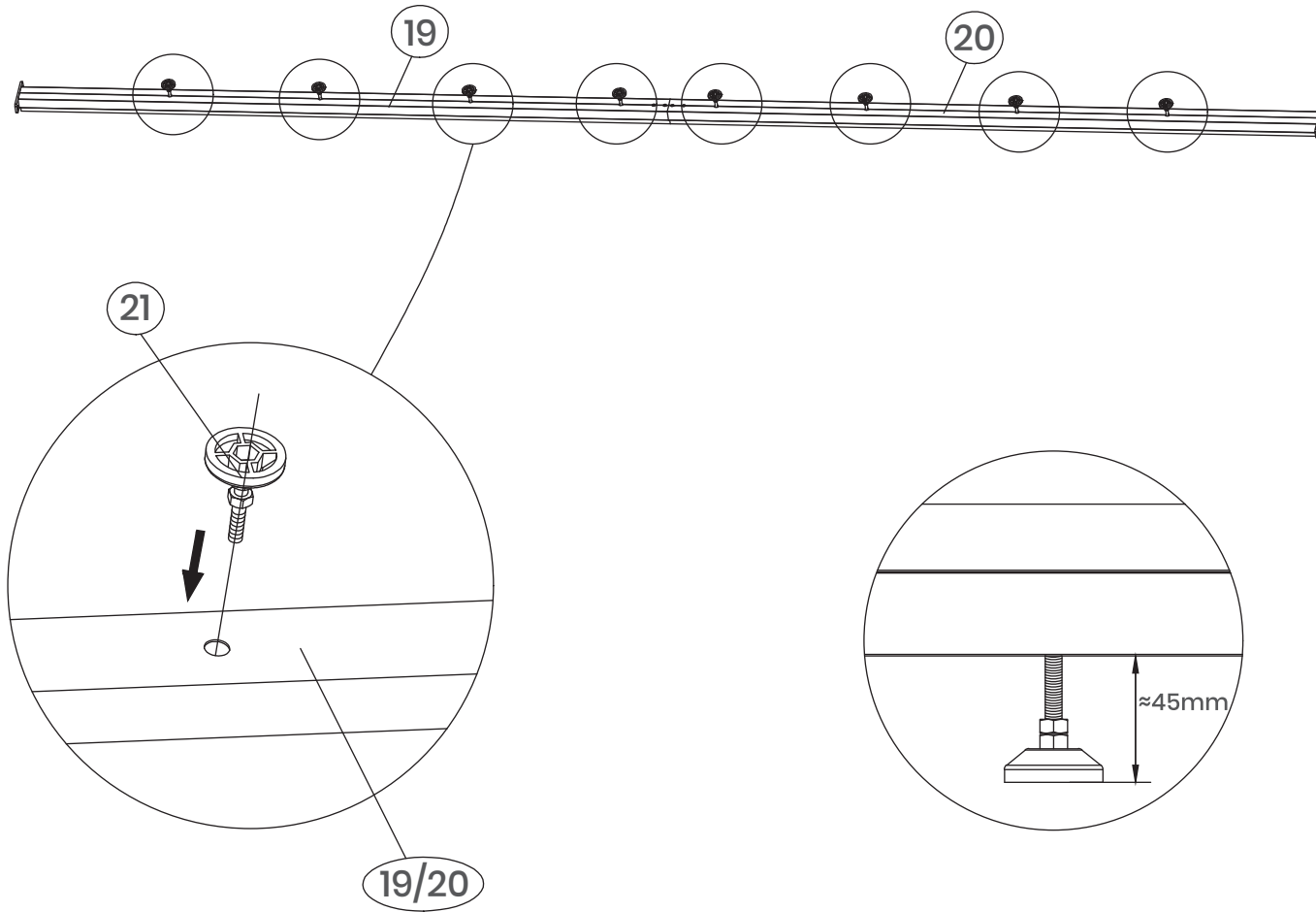

26

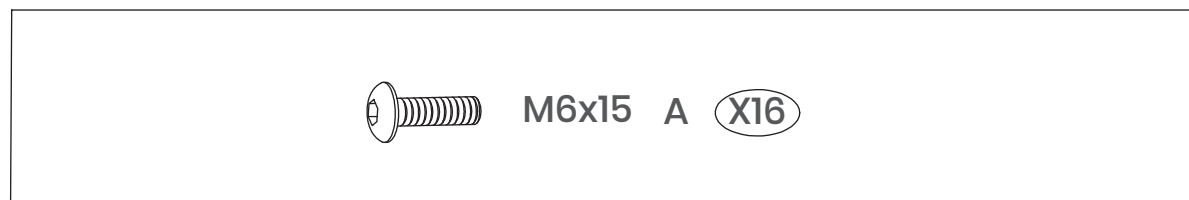
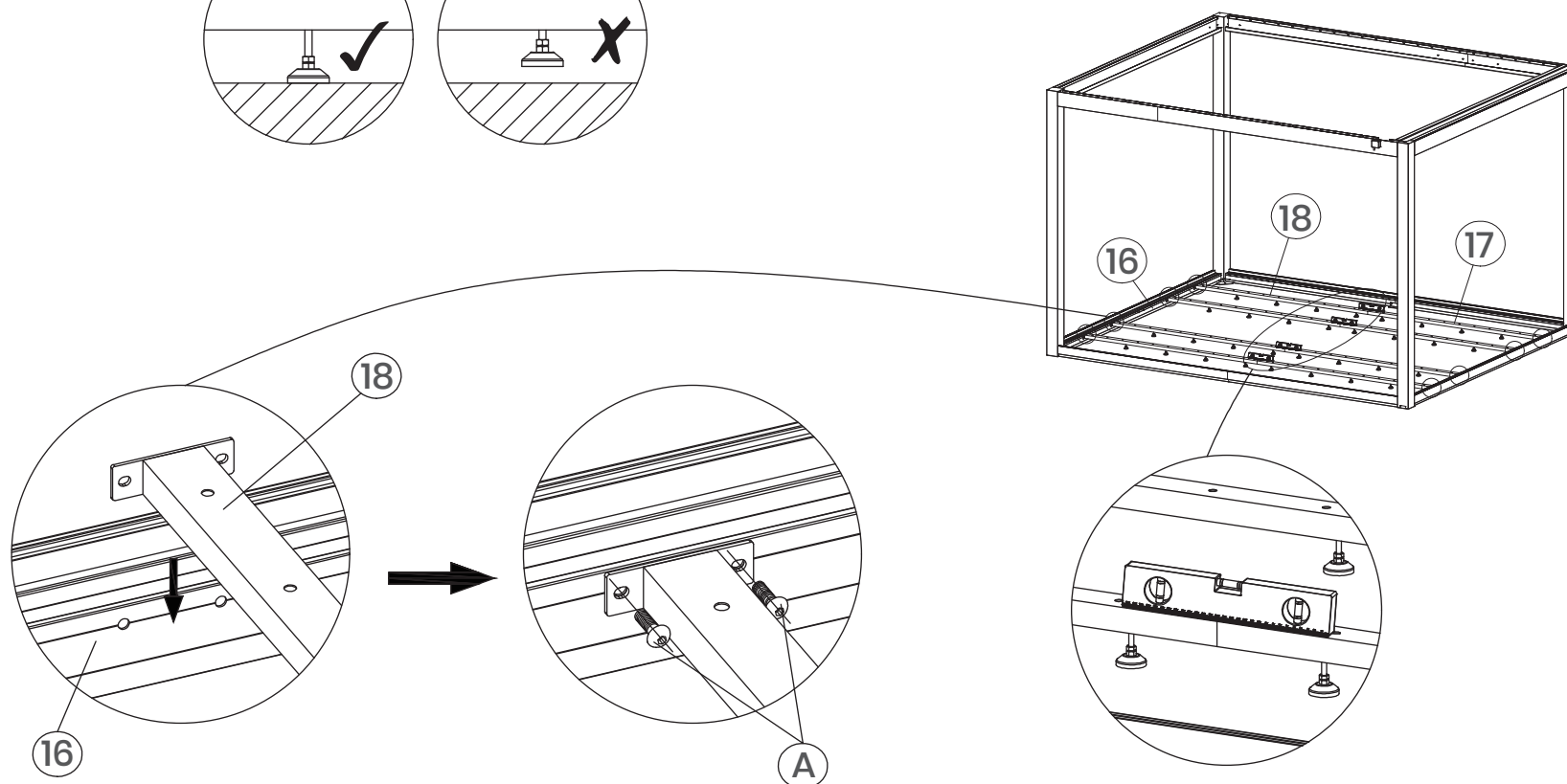
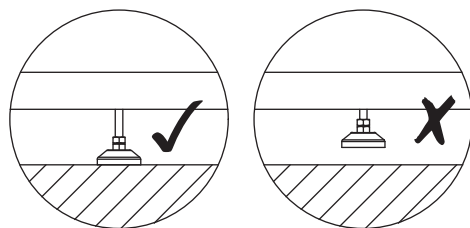

*Structure Assembly / Montage de la structure / Ensamble de la estructura*

27

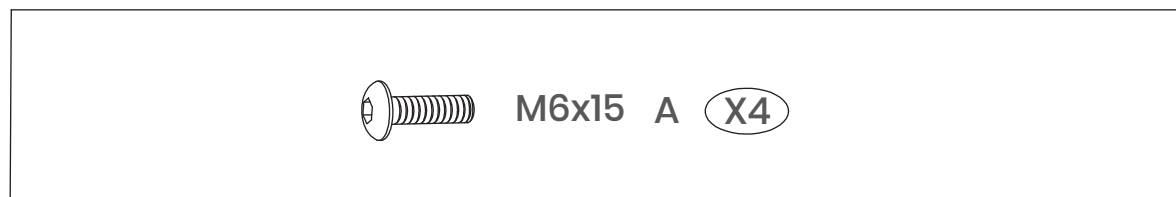
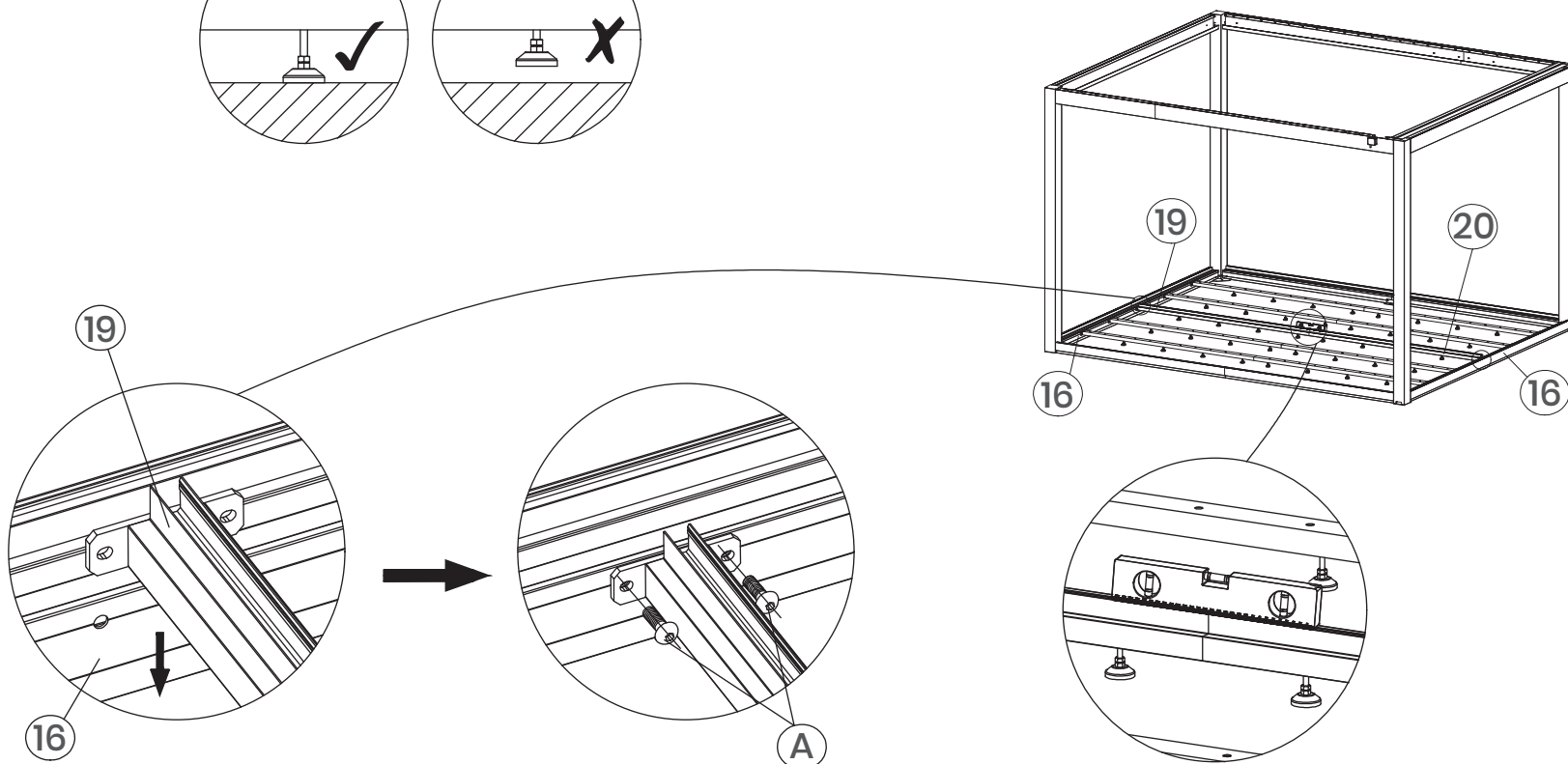
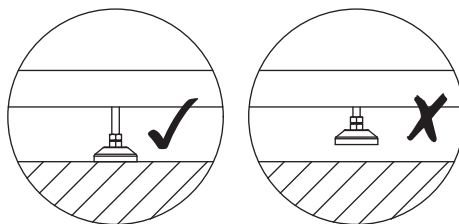

# Structure Assembly / Montage de la structure / Ensamble de la estructura

# 28

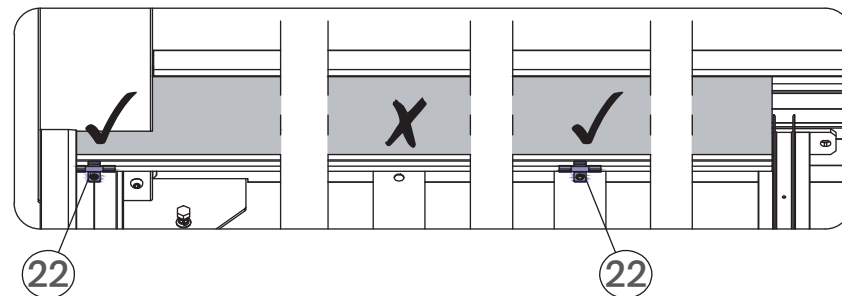
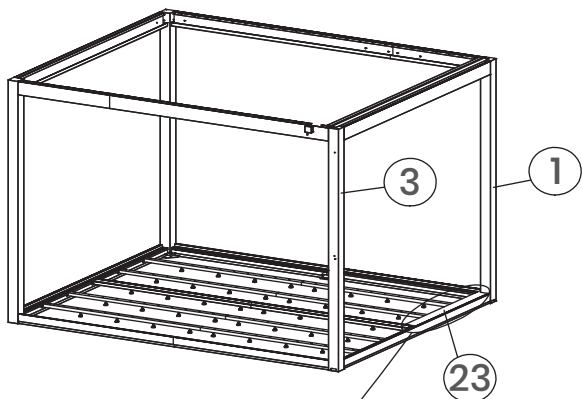

Note: Note: Leave the middle bolt hole, no need to assemble.

Remarque : Laissez le trou de boulon central, aucun assemblage nécessaire. Les étapes suivantes sont identiques.

Nota: Deje el orificio del perno central, no es necesario ensamblarlo. Los pasos siguientes son los mismos.

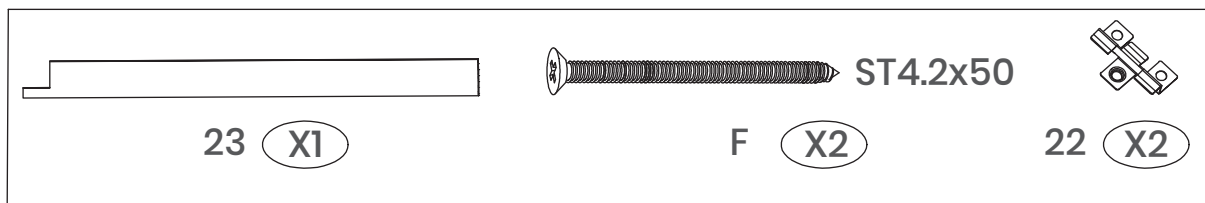
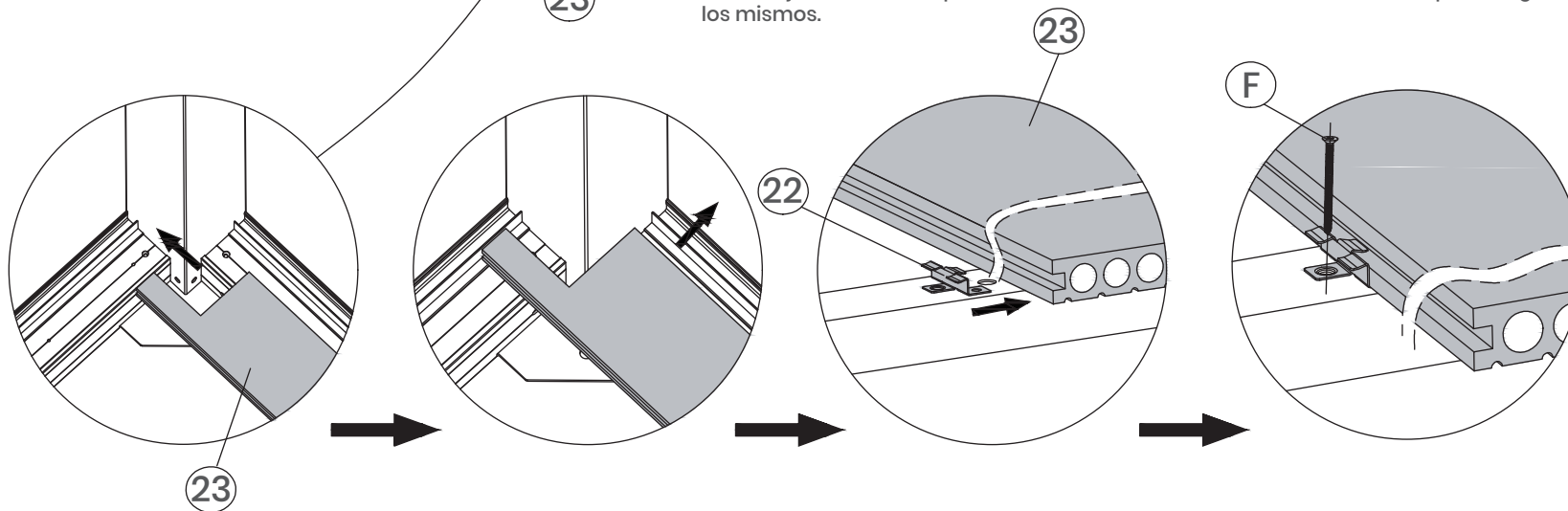

29

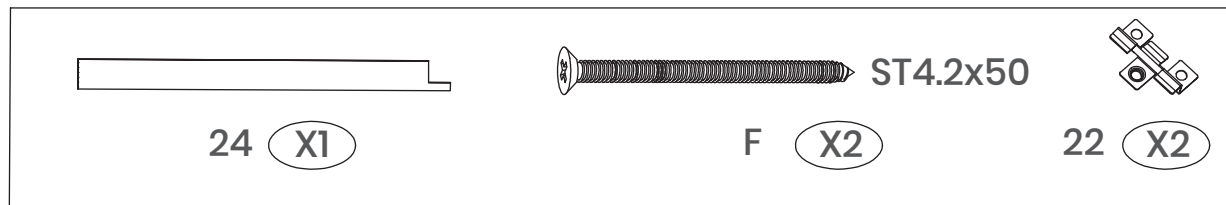
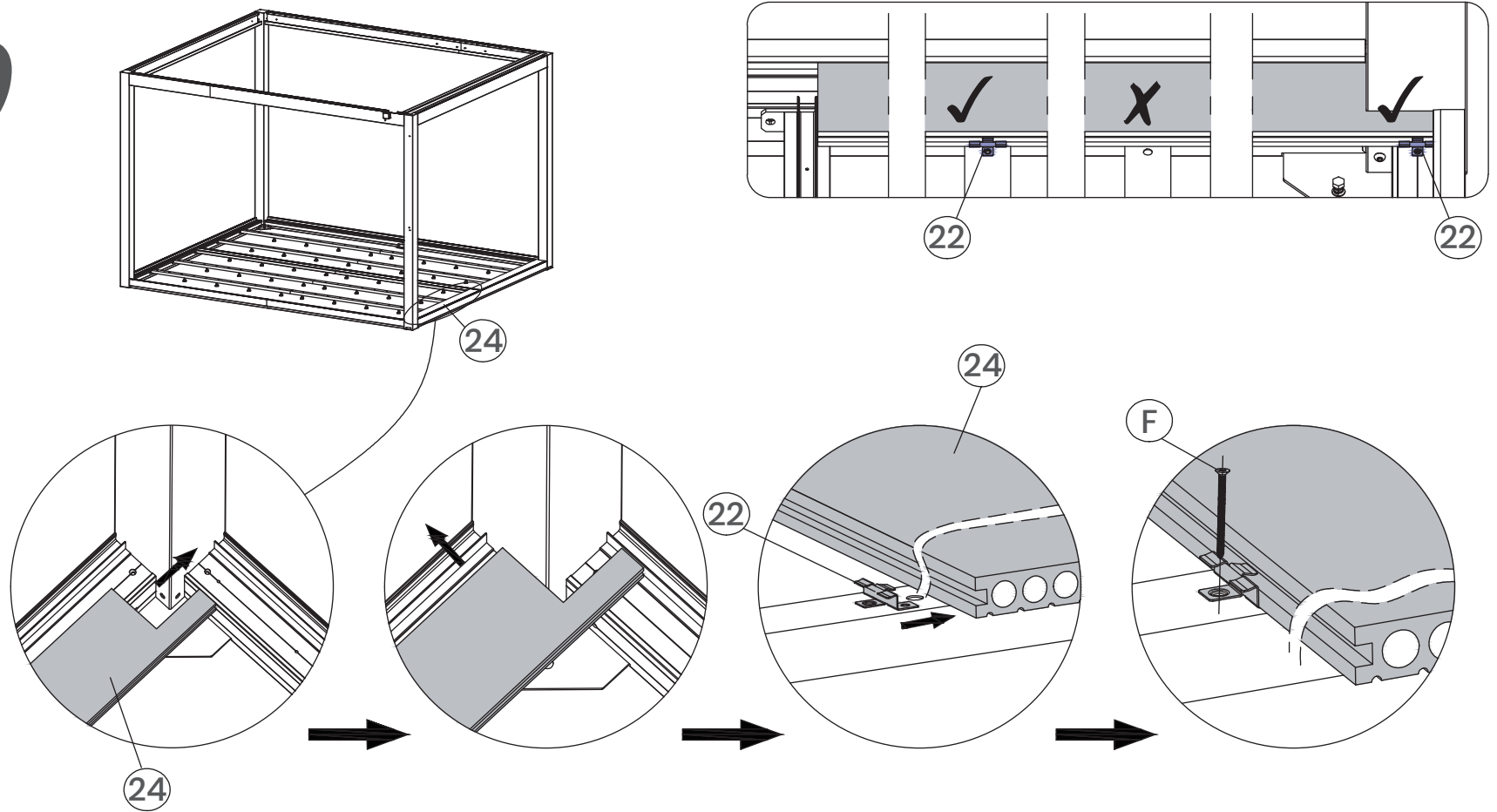

30

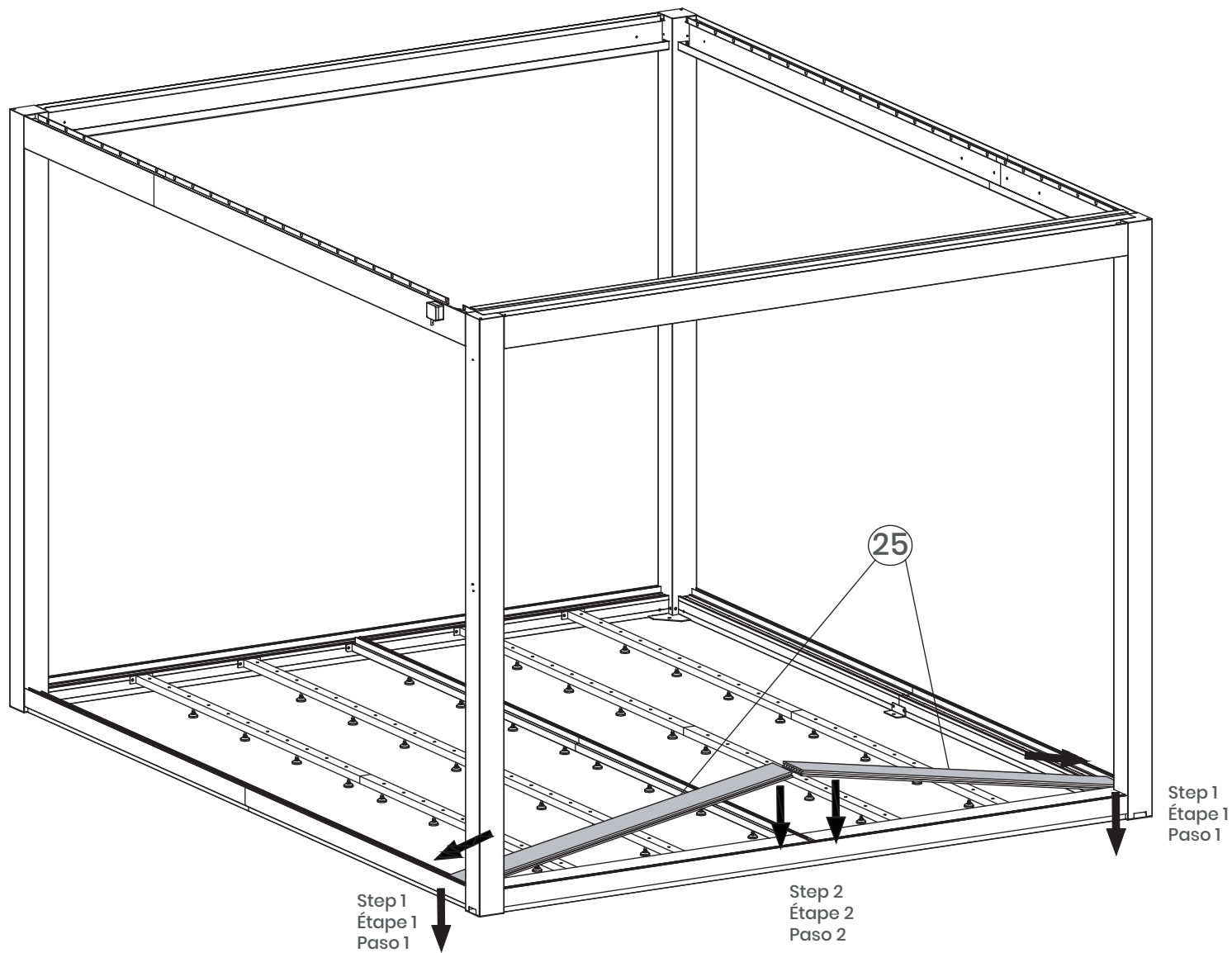

31

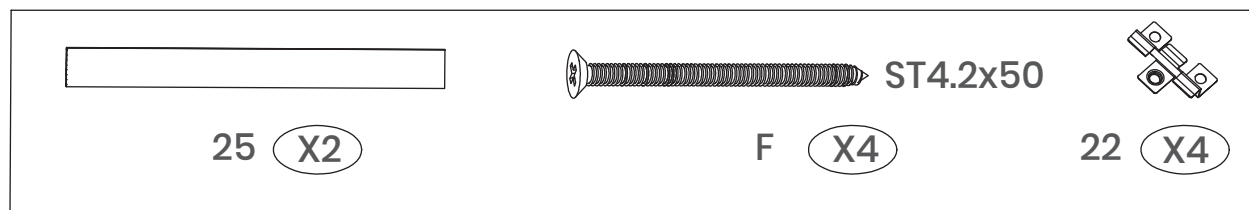
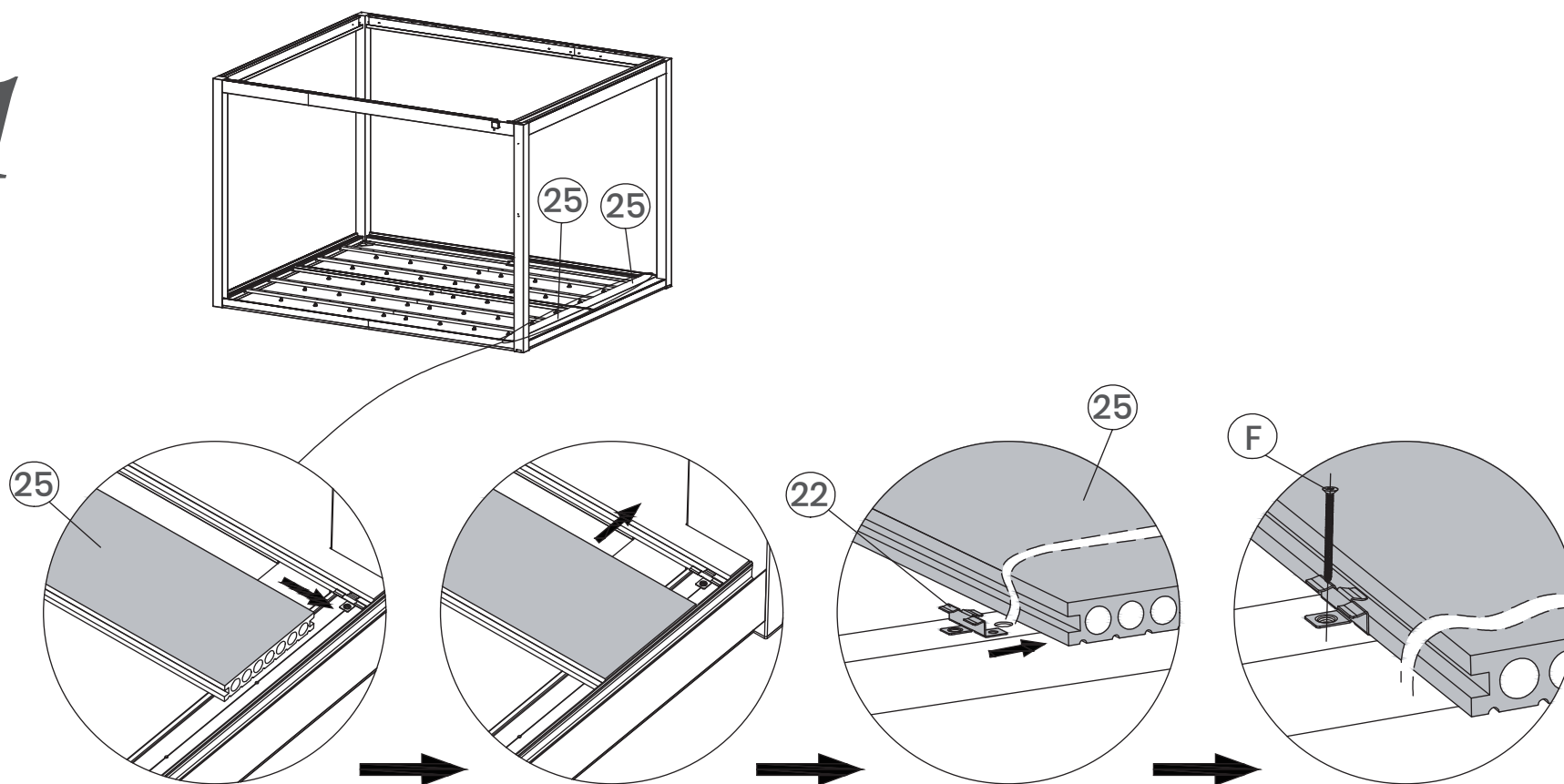

# Structure Assembly / Montage de la structure / Ensamble de la estructura

# 32

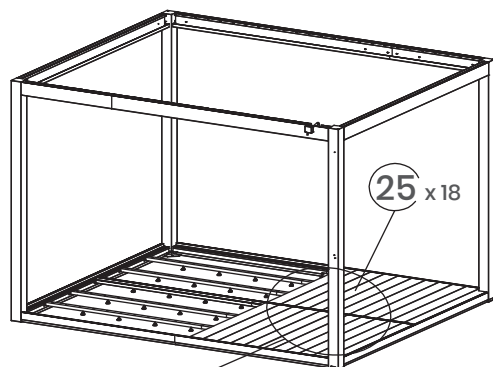

Note: Please repeat step 31 x 9 times.  
Remarque : Veuillez répéter l'étape 31, 9 fois.  
Nota: Repita el paso 31 nueve veces.

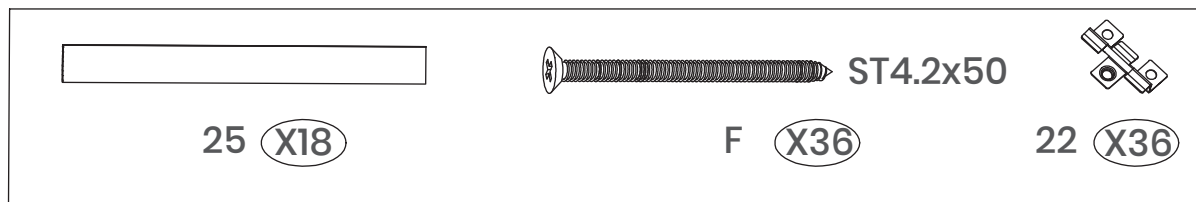
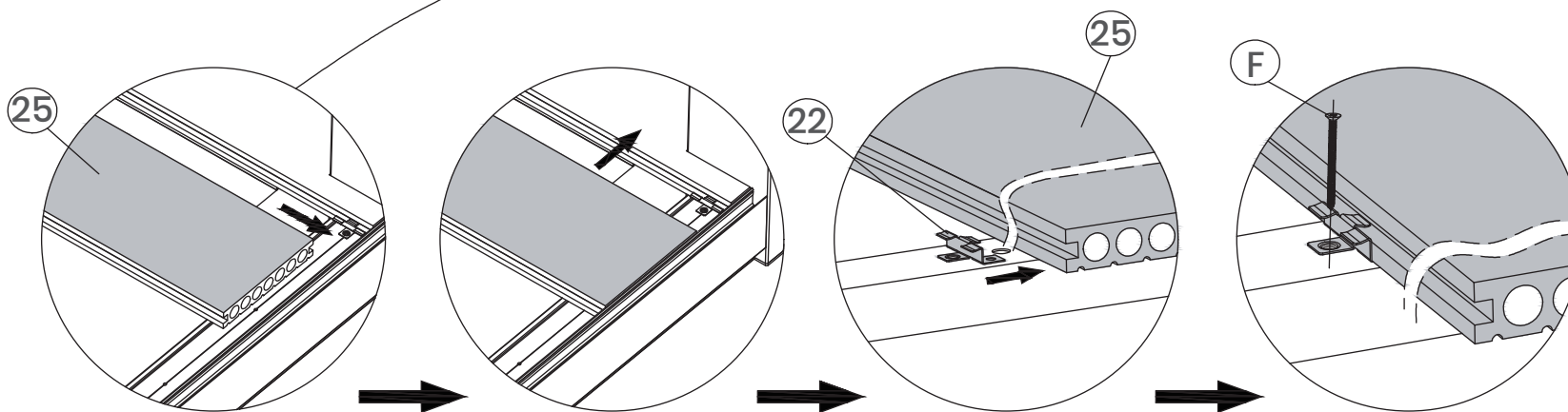

# Structure Assembly / Montage de la structure / Ensamble de la estructura

# 33

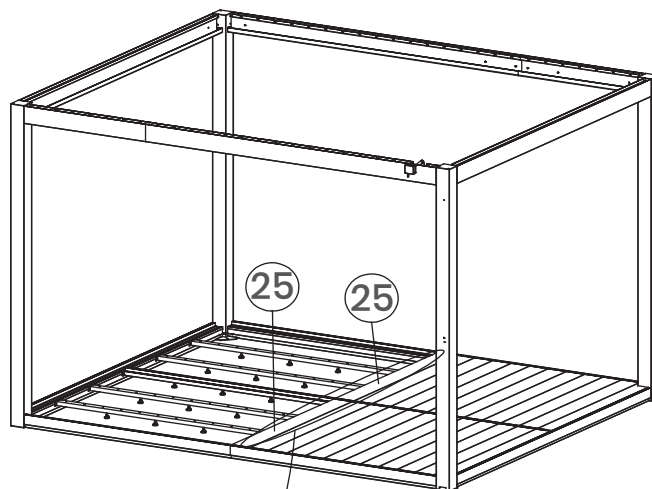

Note: Don't continue decking from this direction after this step.

Remarque : Ne continuez pas la pose de la terrasse dans cette direction après cette étape.

Nota: No continúe colocando la plataforma desde esta dirección después de este paso.

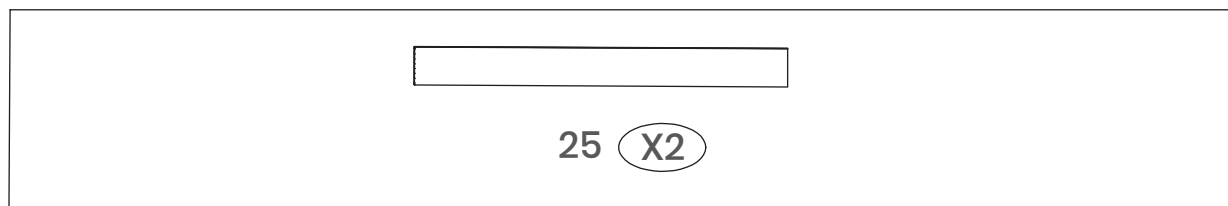
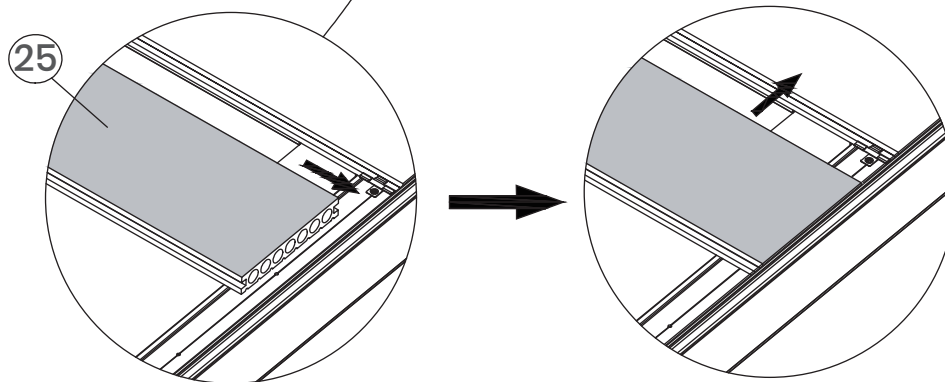

34

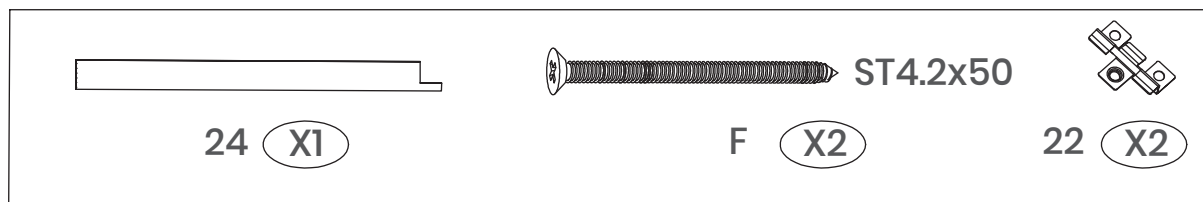
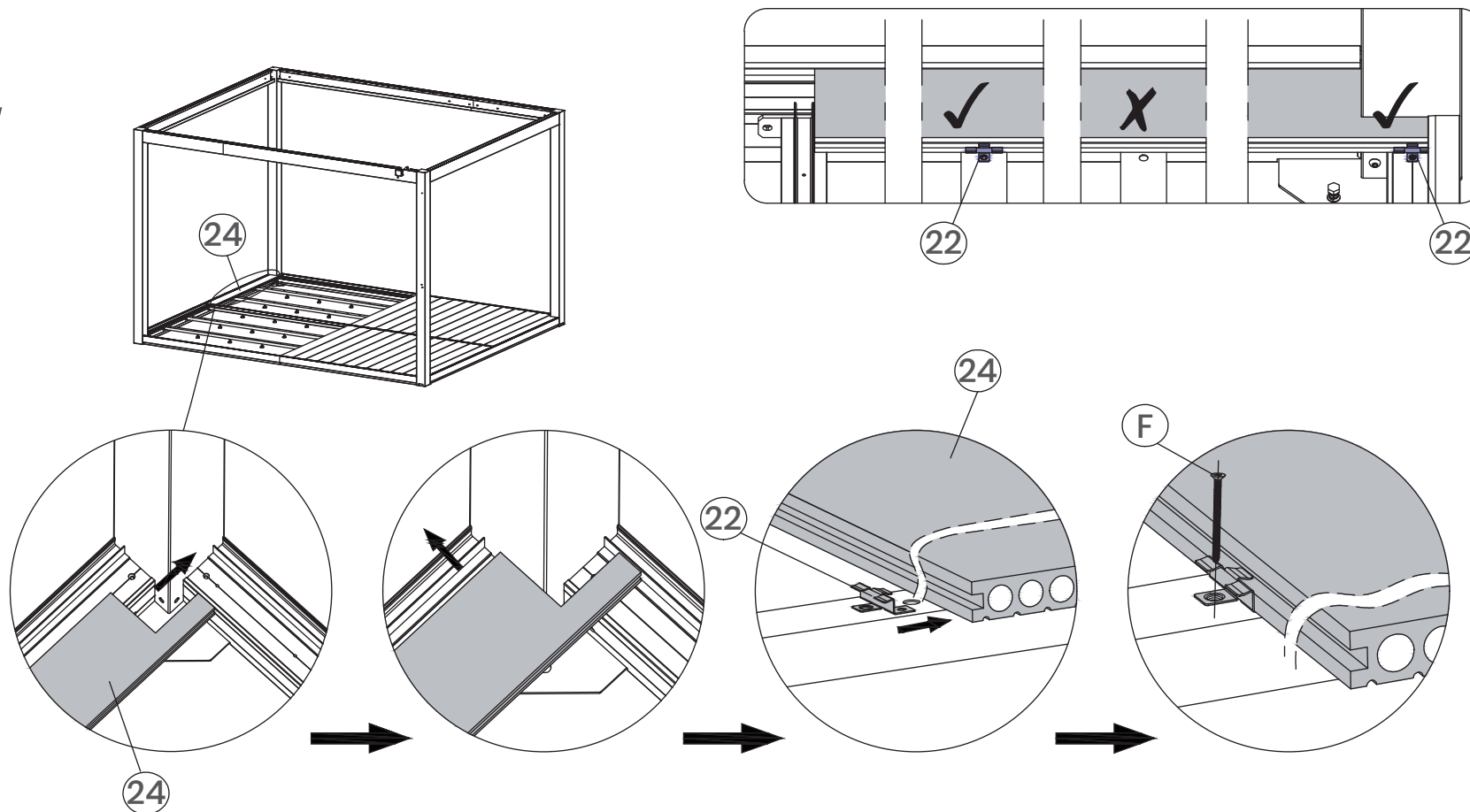

35

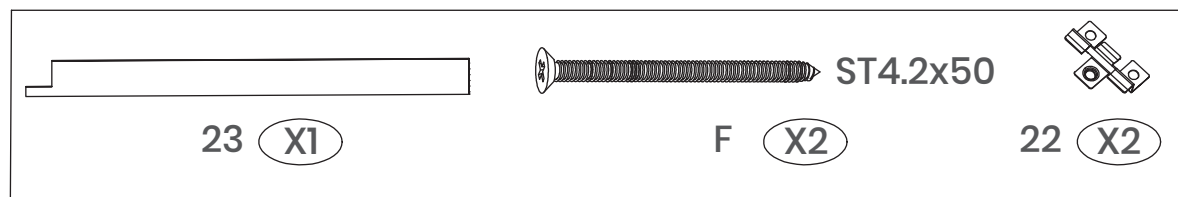
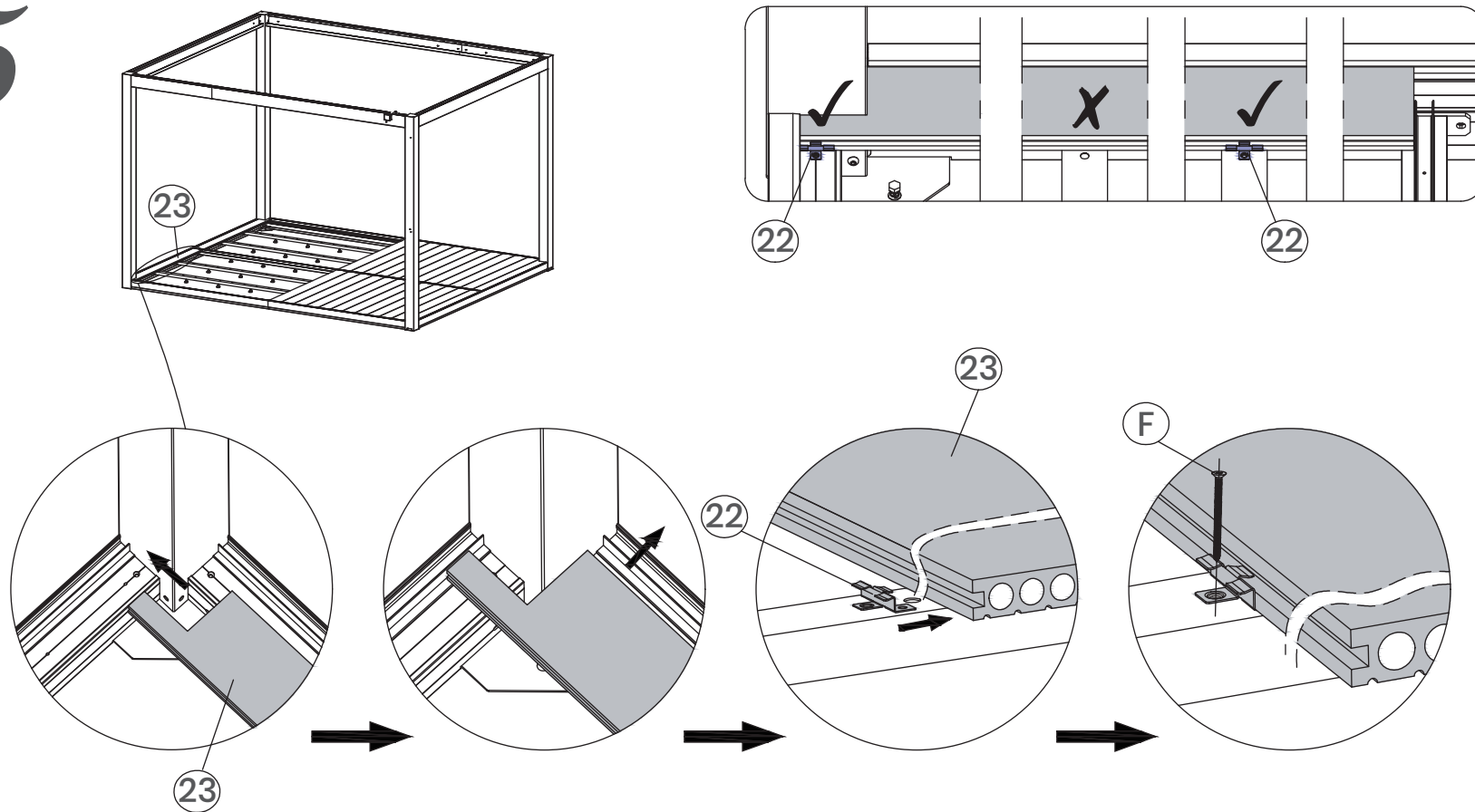

*Structure Assembly / Montage de la structure / Ensamble de la estructura*

36

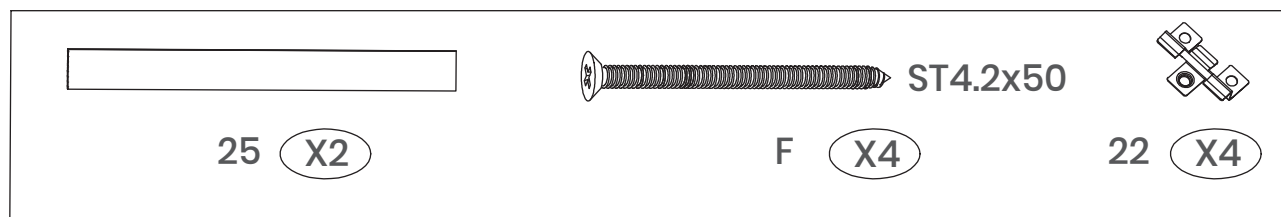
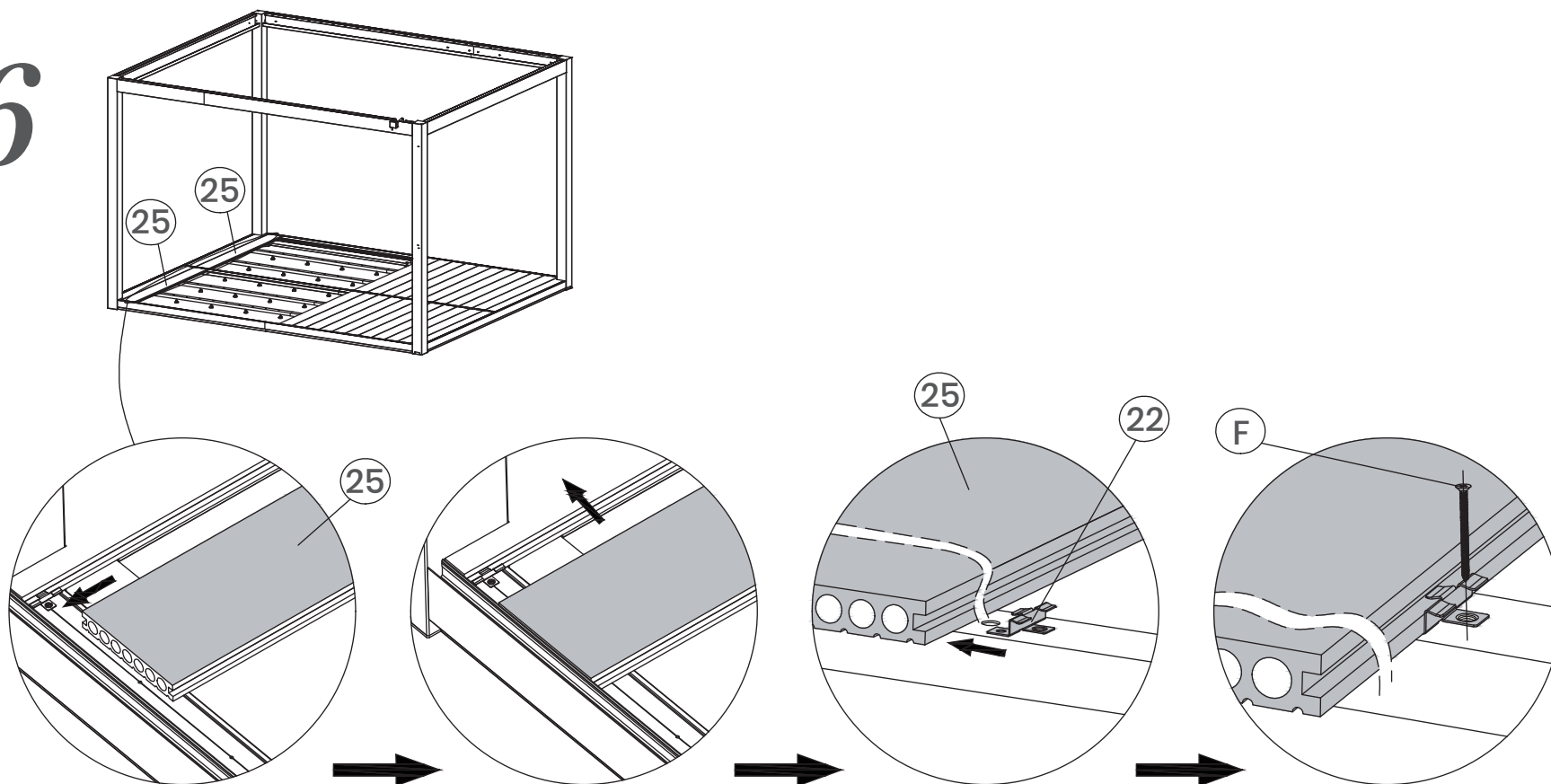

# Structure Assembly / Montage de la structure / Ensamble de la estructura

# 37

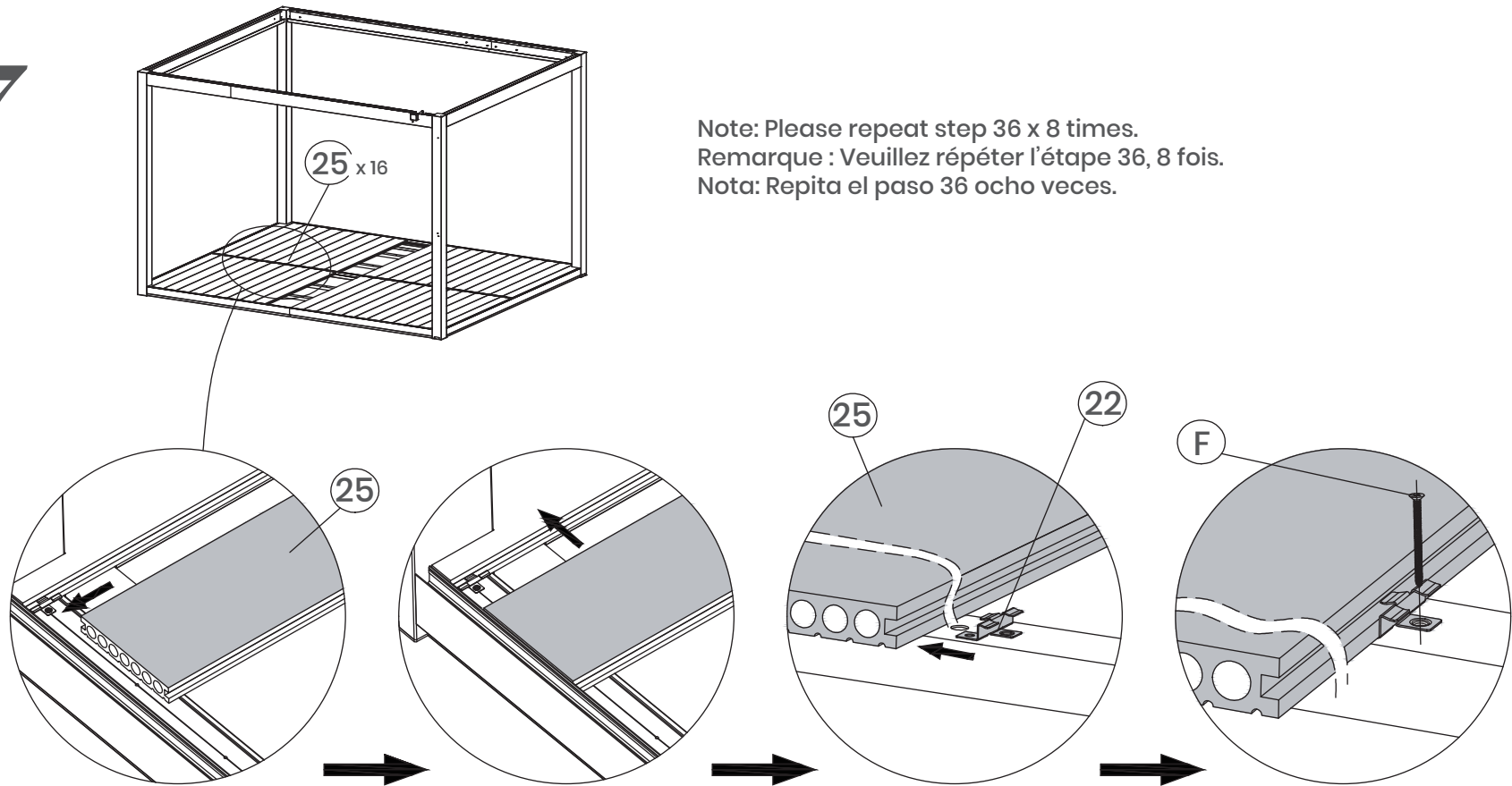

Note: Please repeat step 36 x 8 times.  
Remarque : Veuillez répéter l'étape 36, 8 fois.  
Nota: Repita el paso 36 ocho veces.

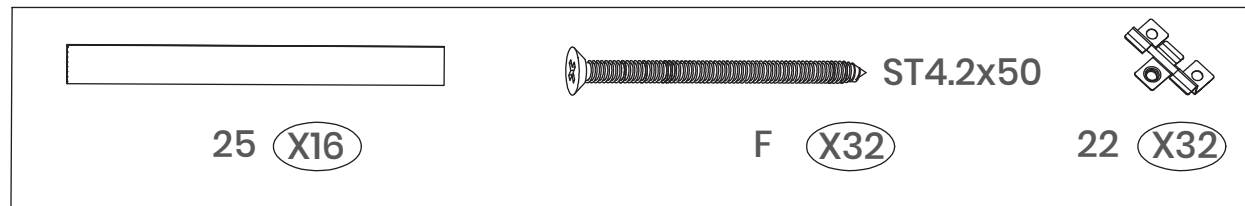

# 38

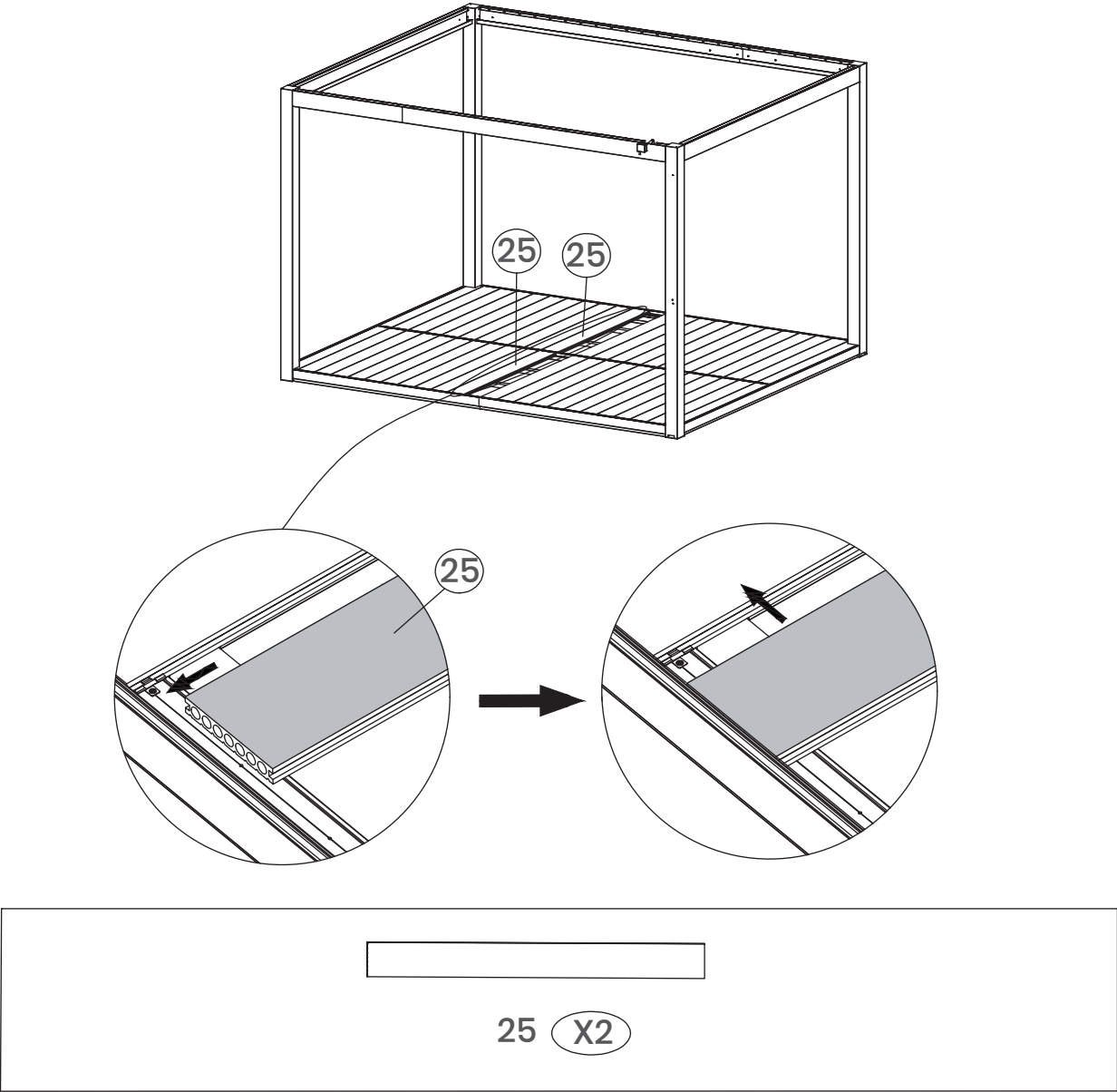

39

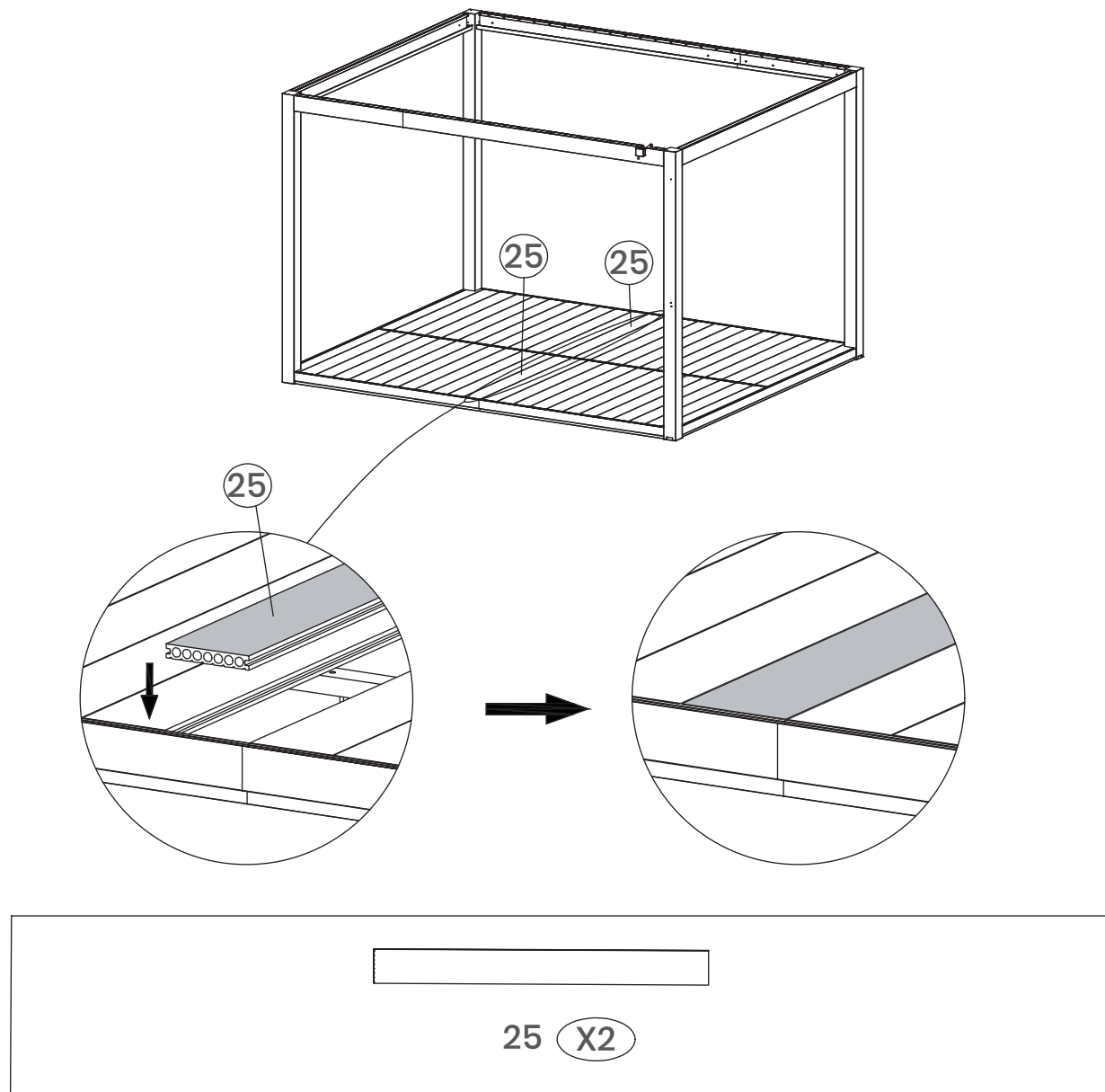

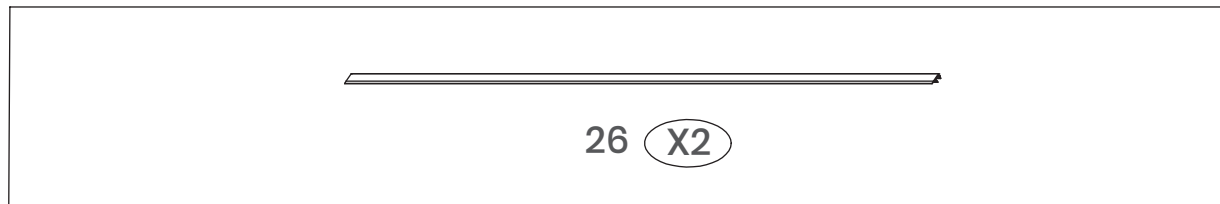
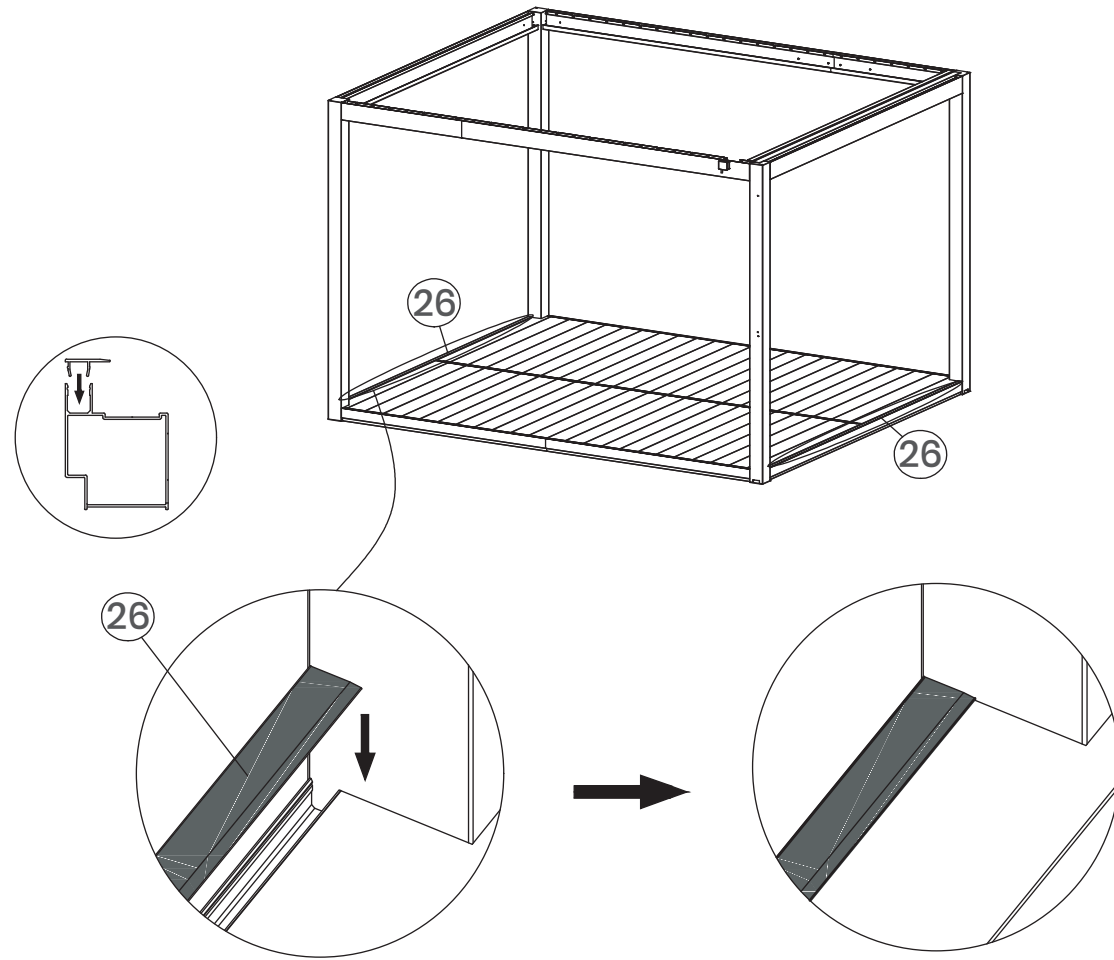

40

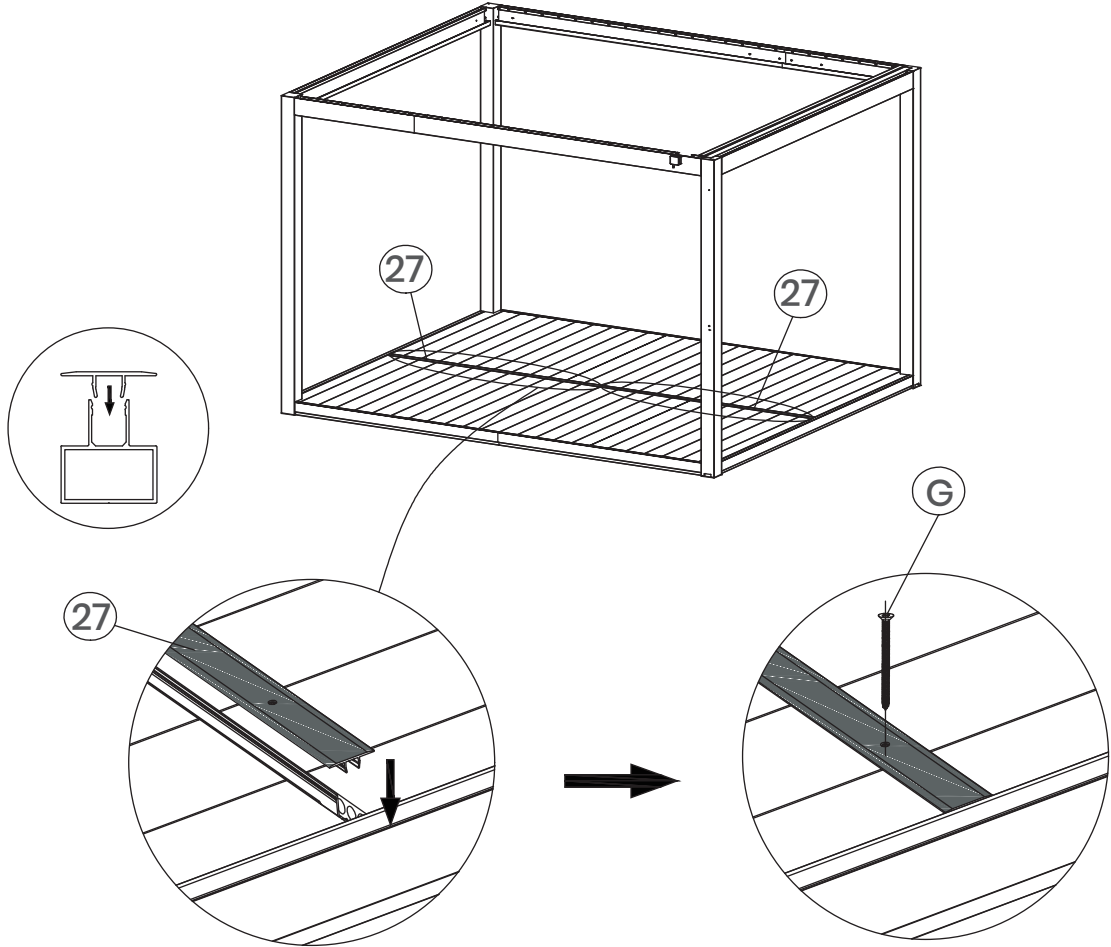

# 41



		ST4x40
27 (X2)	G (X8)	

42

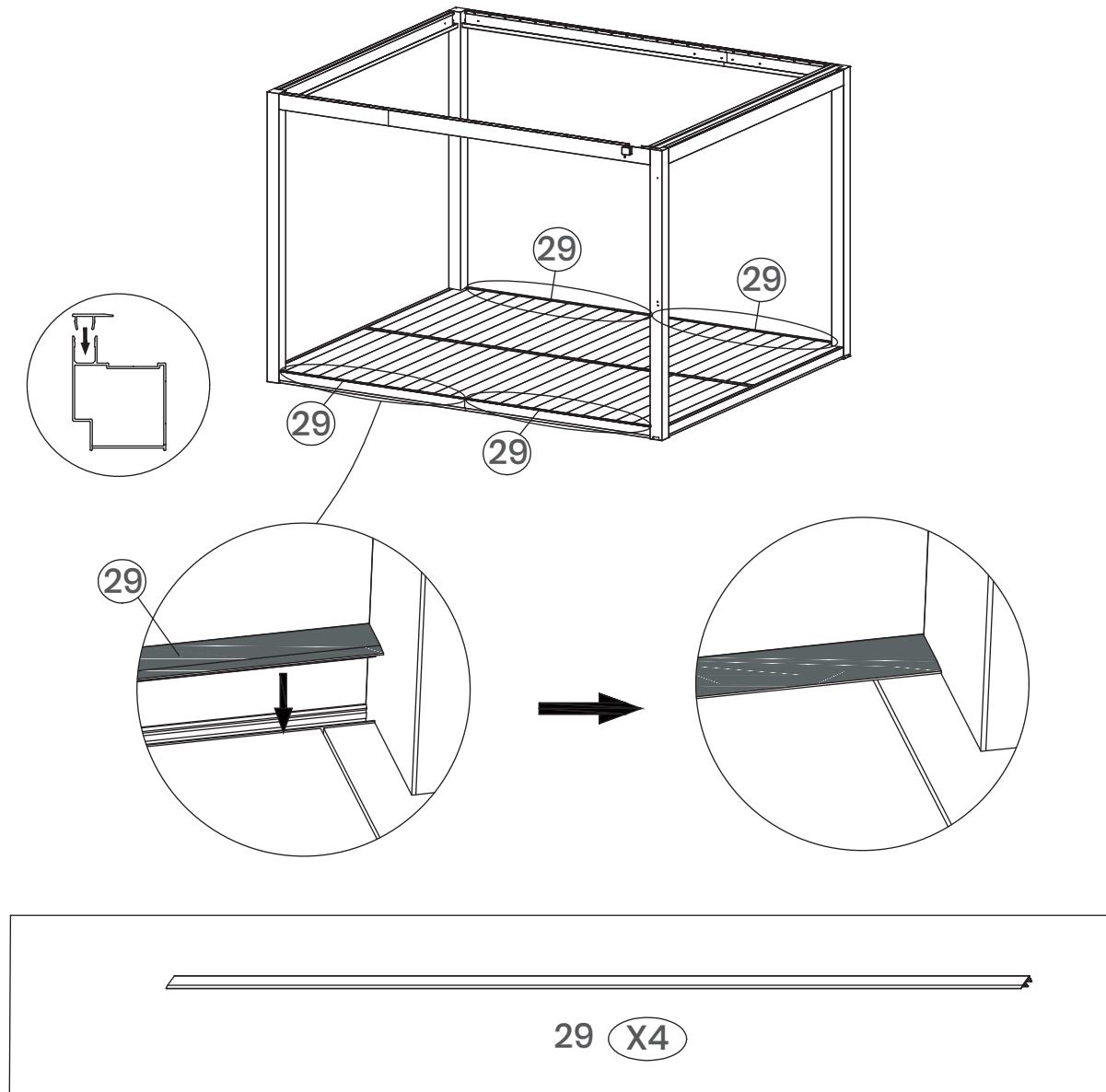

# 43

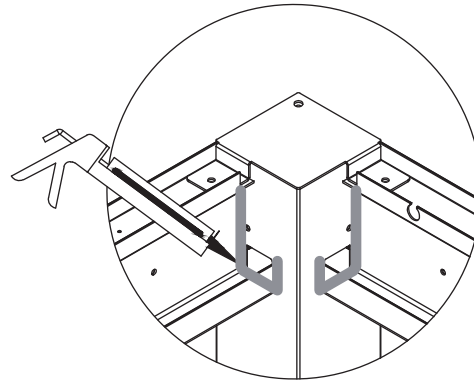
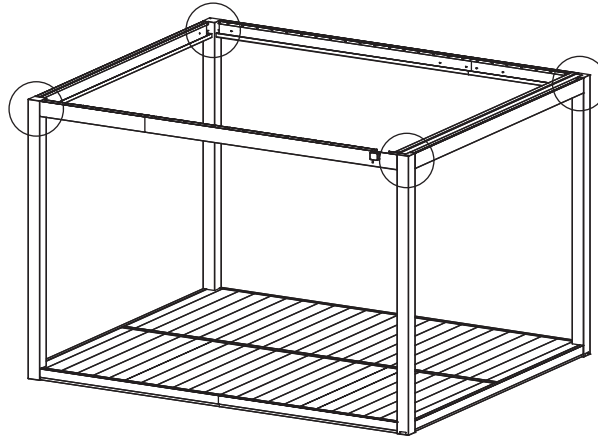

Note: Silicone neutral glass glue is needed here to prevent water leakage.

Remarque : La colle à verre à base de silicone neutre sert à empêcher les fuites d'eau.

Nota: Aquí se necesita pegamento de silicona neutro para vidrio para evitar fugas de agua.

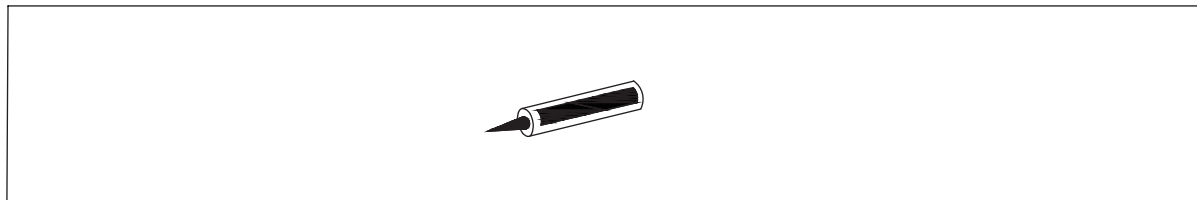

# Structure Assembly / Montage de la structure / Ensamble de la estructura

# 44

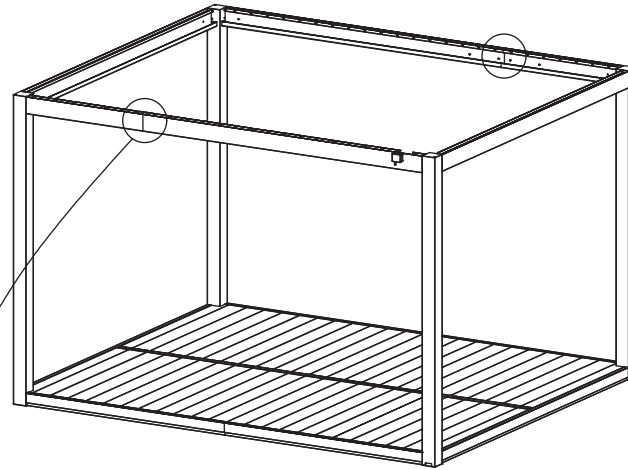

Note: Silicone neutral glass glue is needed here to prevent water leakage.

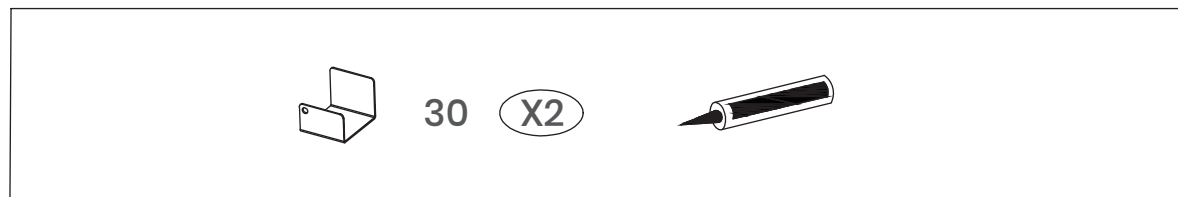
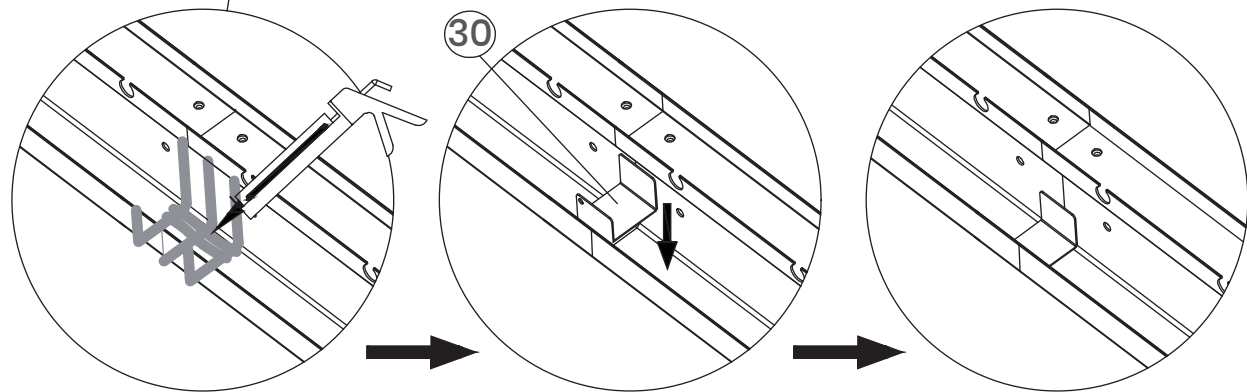

Remarque : La colle à verre à base de silicone neutre sert à empêcher les fuites d'eau.

Nota: Aquí se necesita pegamento de silicona neutro para vidrio para evitar fugas de agua.

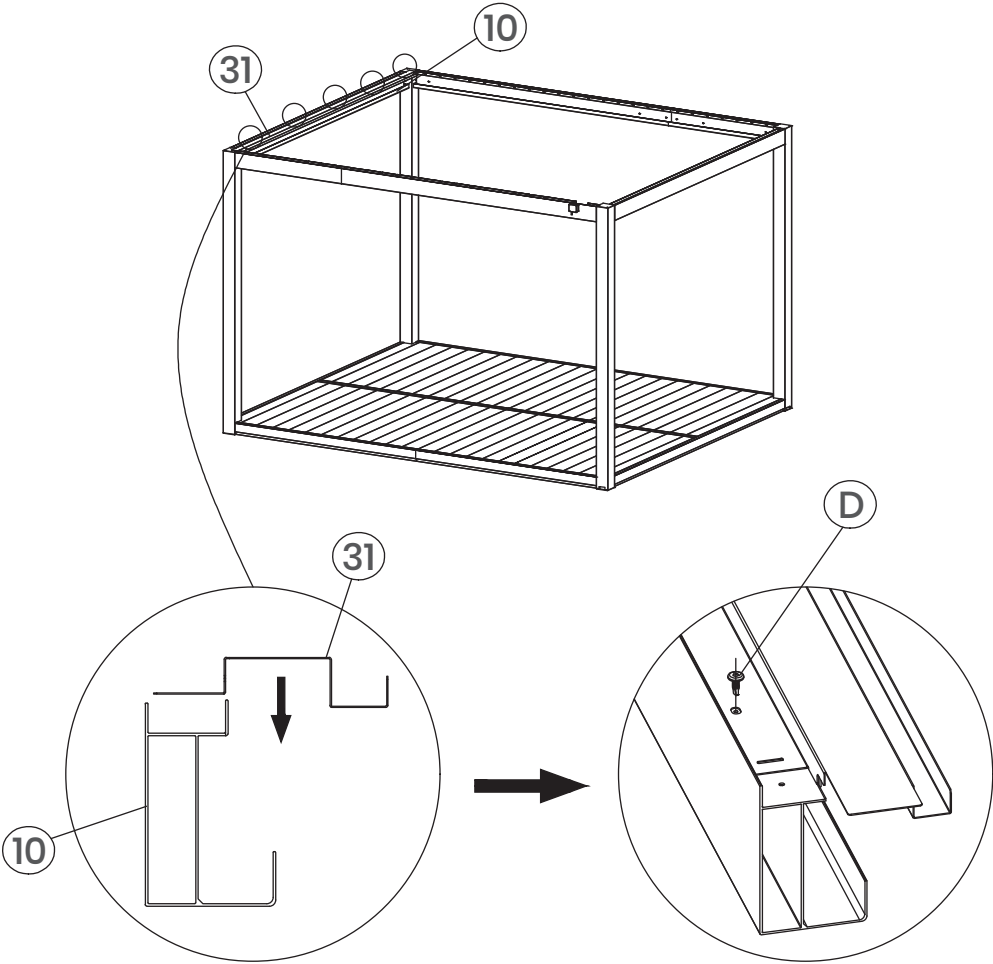

# 45



	
31 (X1)	M5x15 D (X5)

46

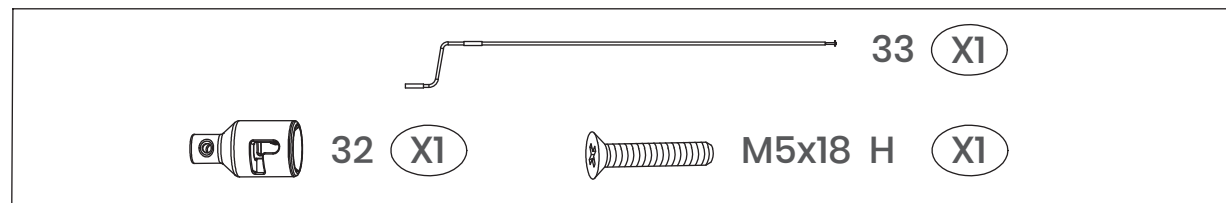
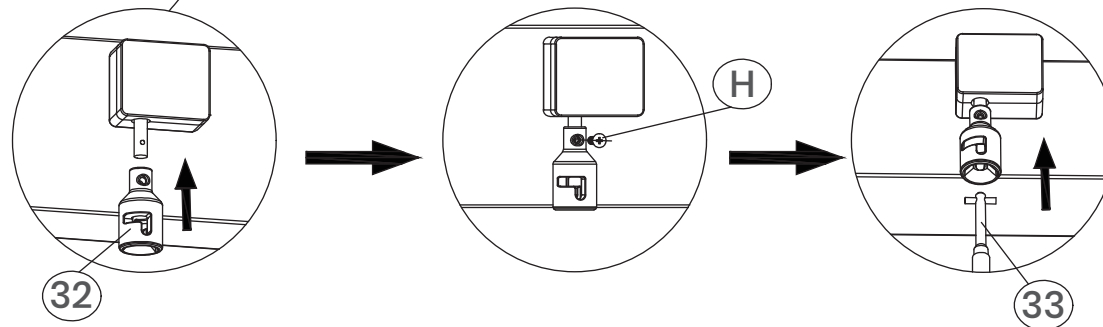
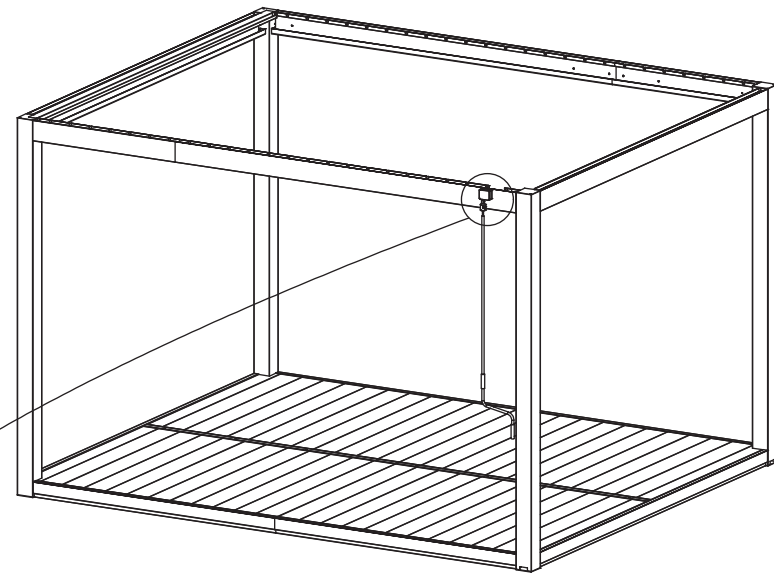
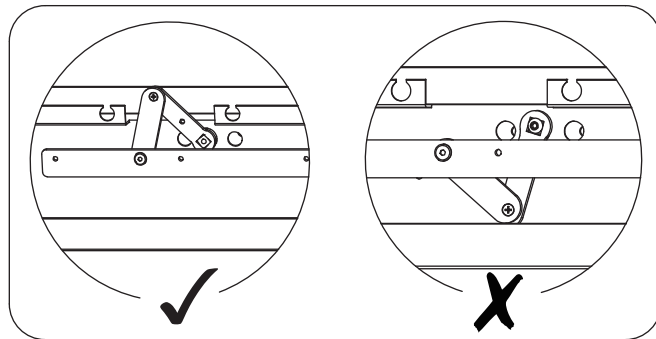

Structure Assembly / Montage de la structure / Ensamble de la estructura

47

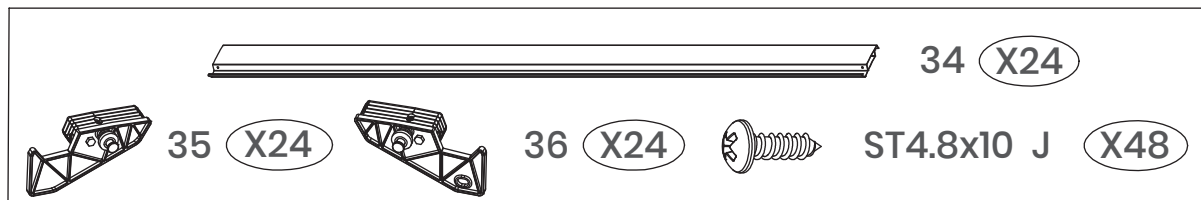
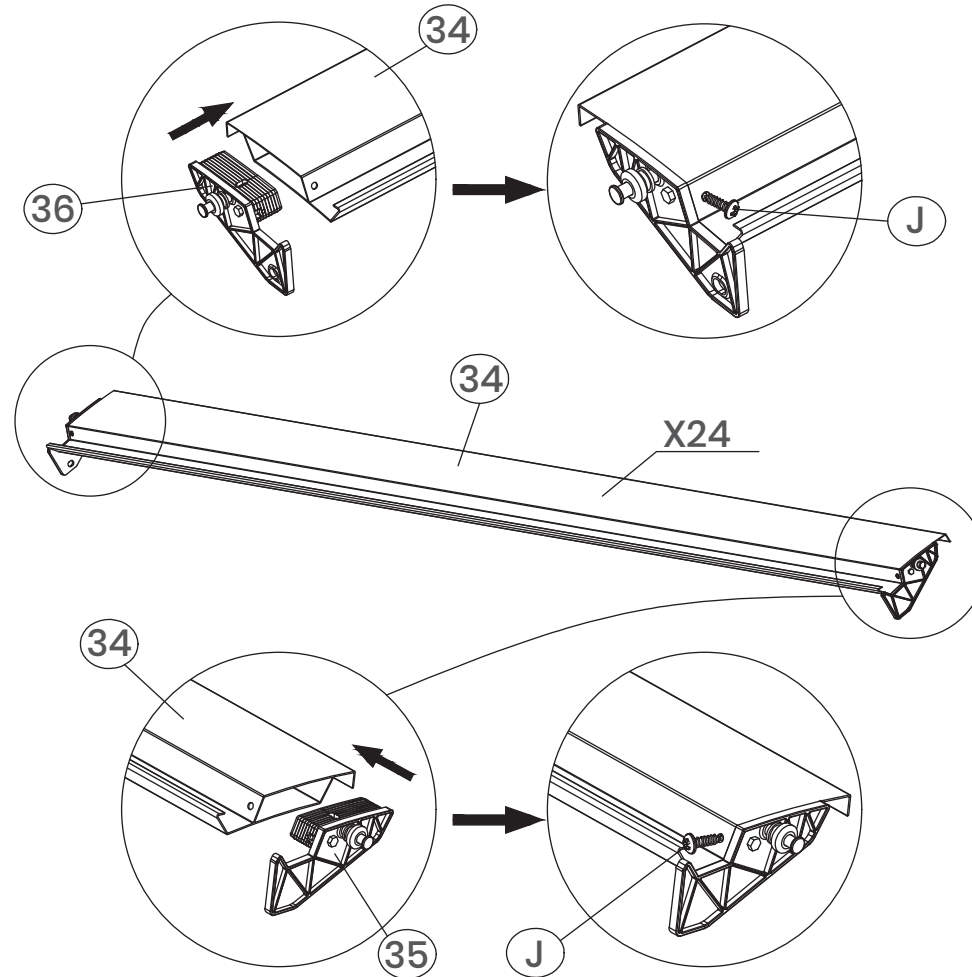

## Structure Assembly / Montage de la structure / Ensemble de la estructura

# 48

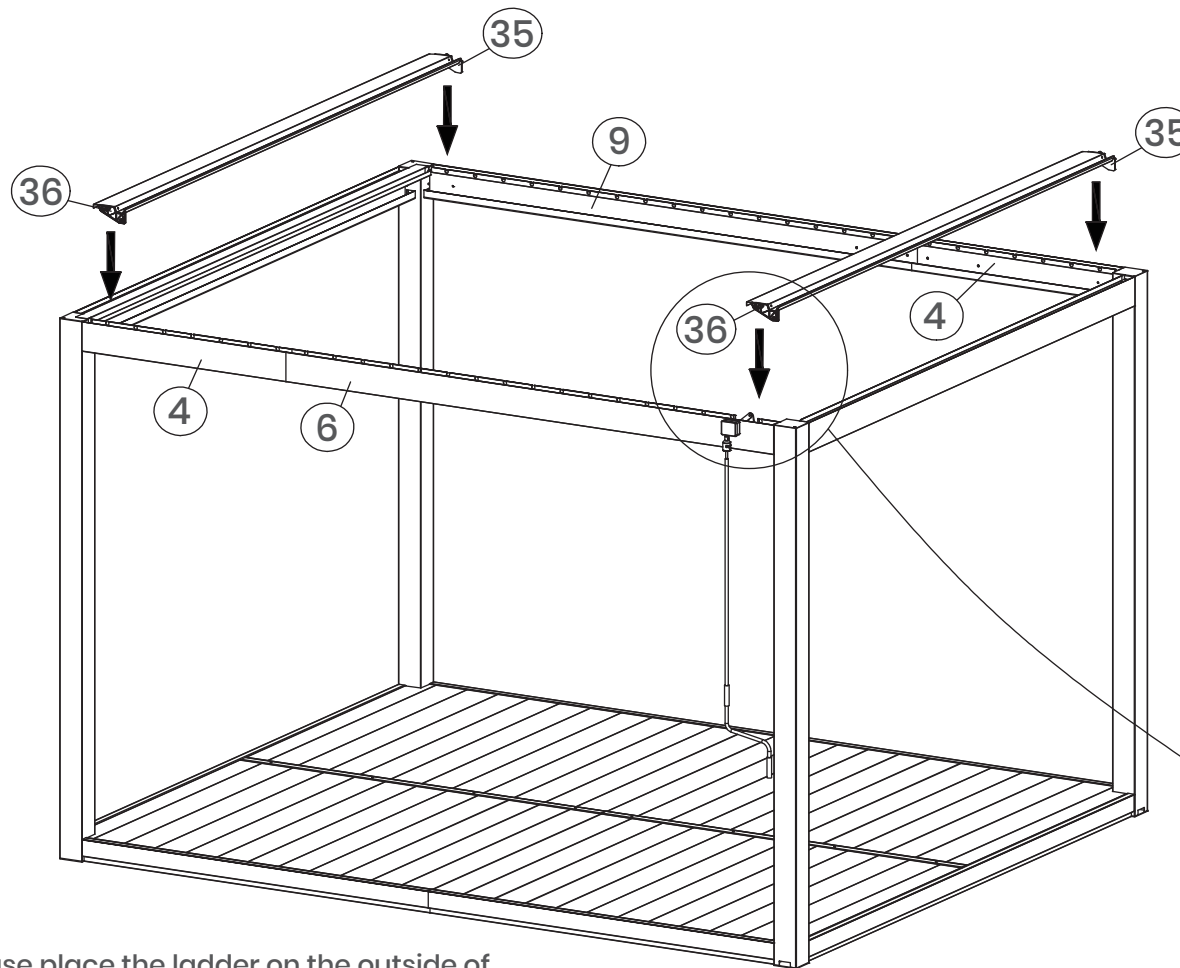

Note: Do not assemble the louvers backwards.

Remarque : N'assemblez pas les lames à l'envers.

Nota: No ensamble las lamas al revés.

Note: Please place the ladder on the outside of the pergola to assemble the louvers.

Remarque : Veuillez placer l'échelle à l'extérieur de la structure.

Nota: Coloque la escalera en el exterior de la estructura.

# 49

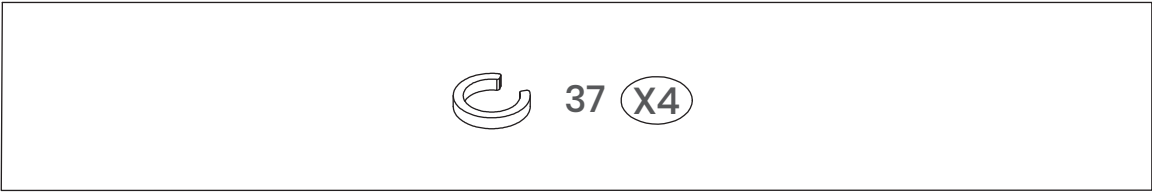
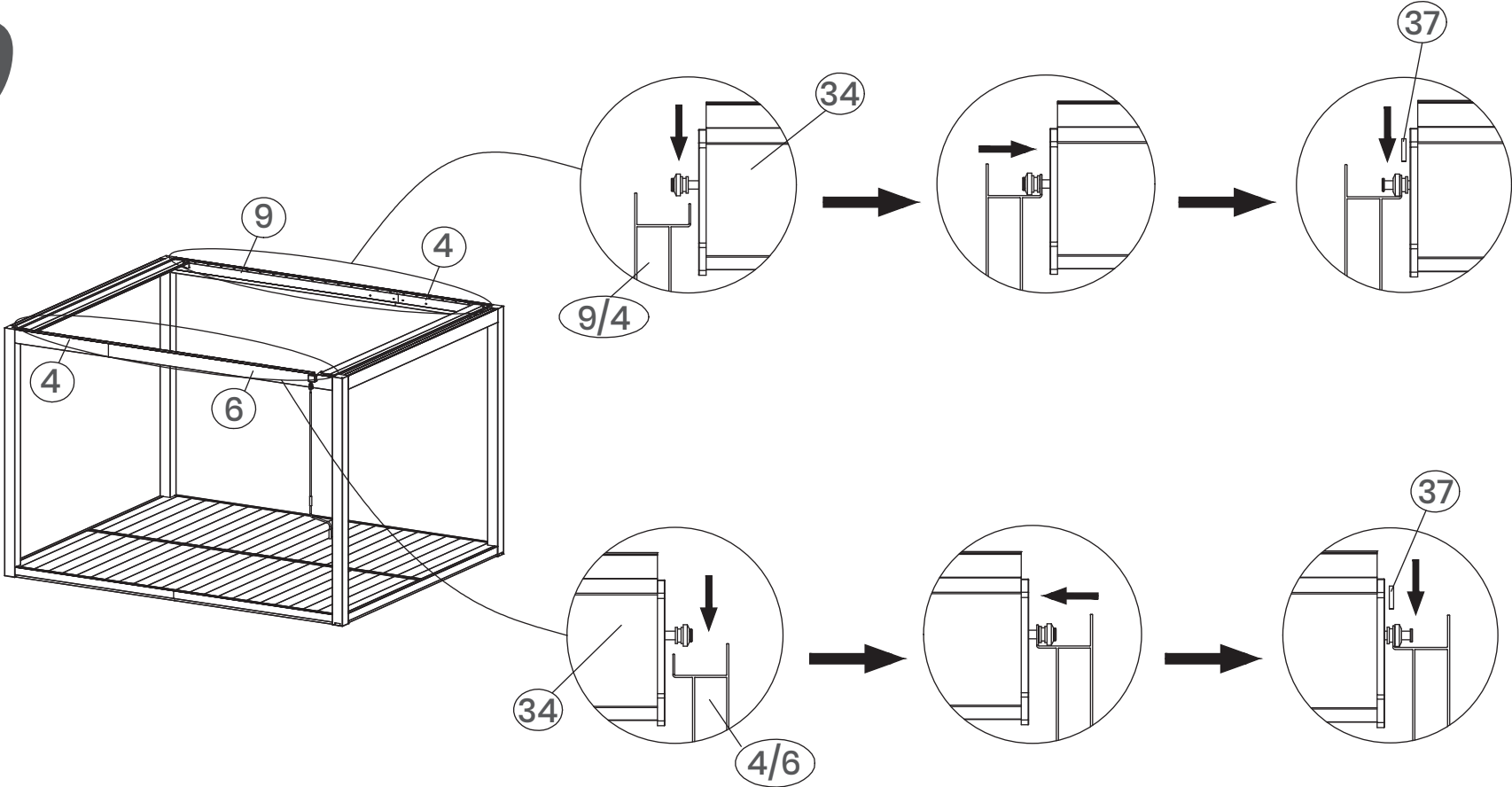

50

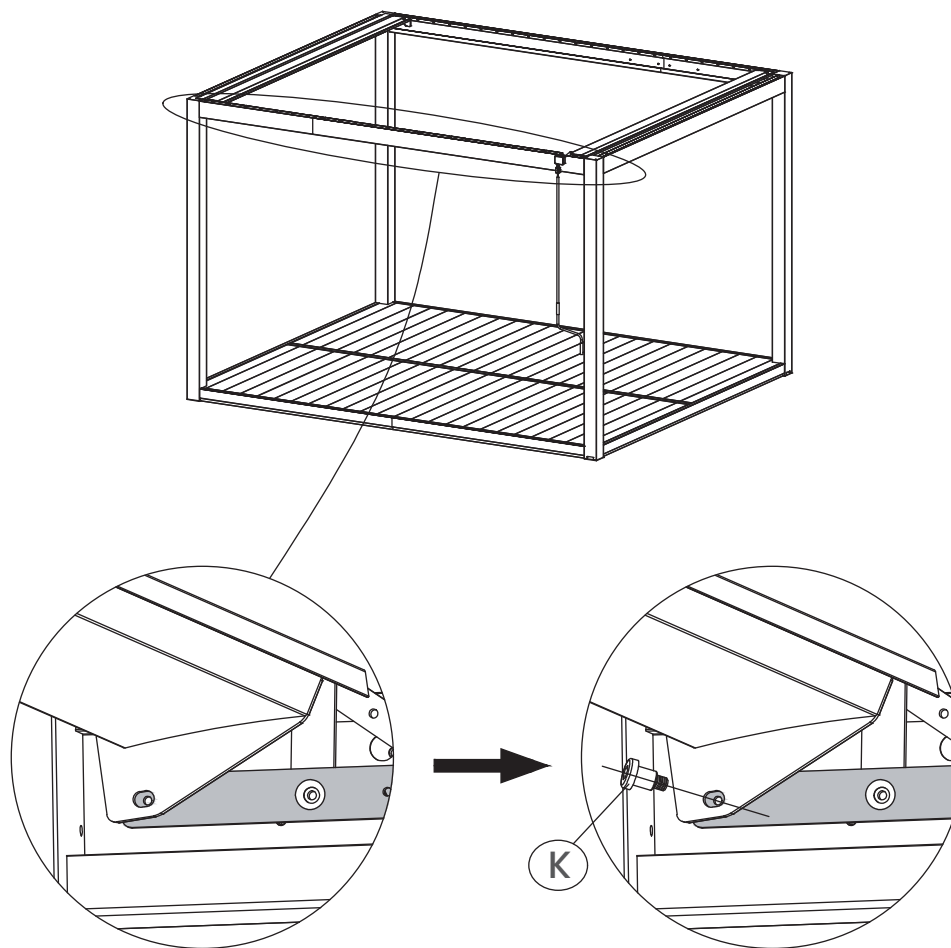

 Ø8.8x10xM6x5 K (X2)

51

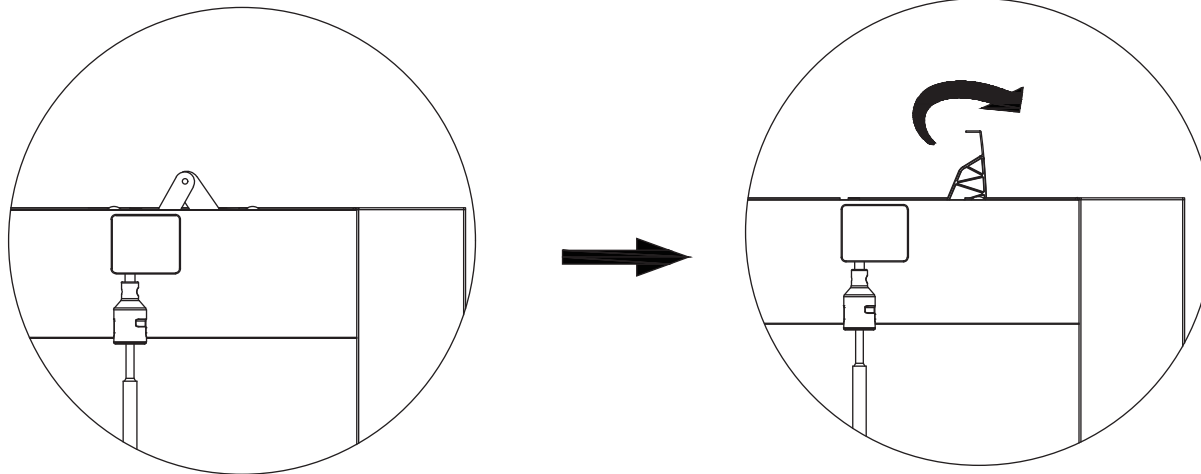
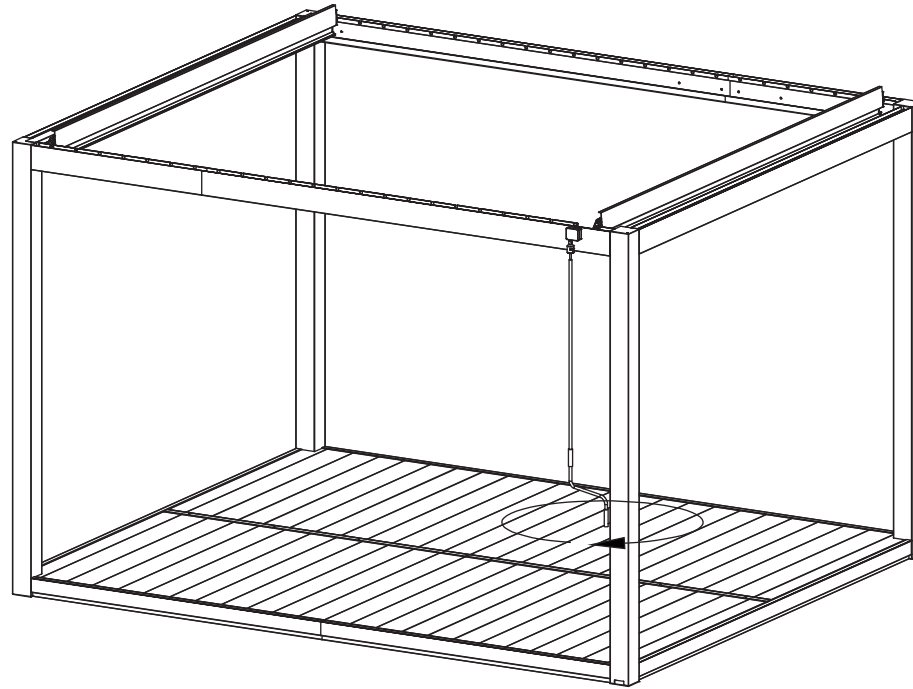

52

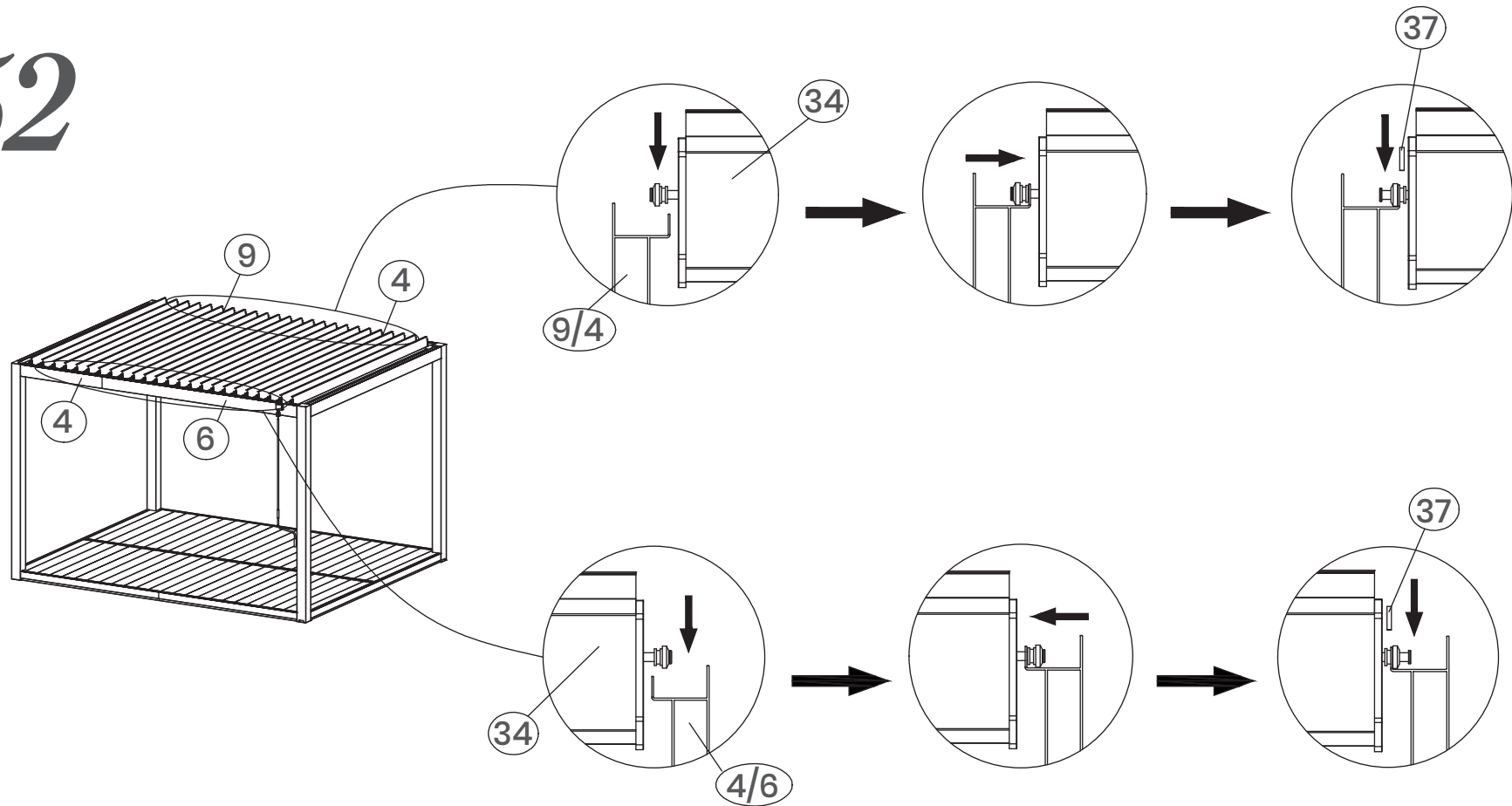

53

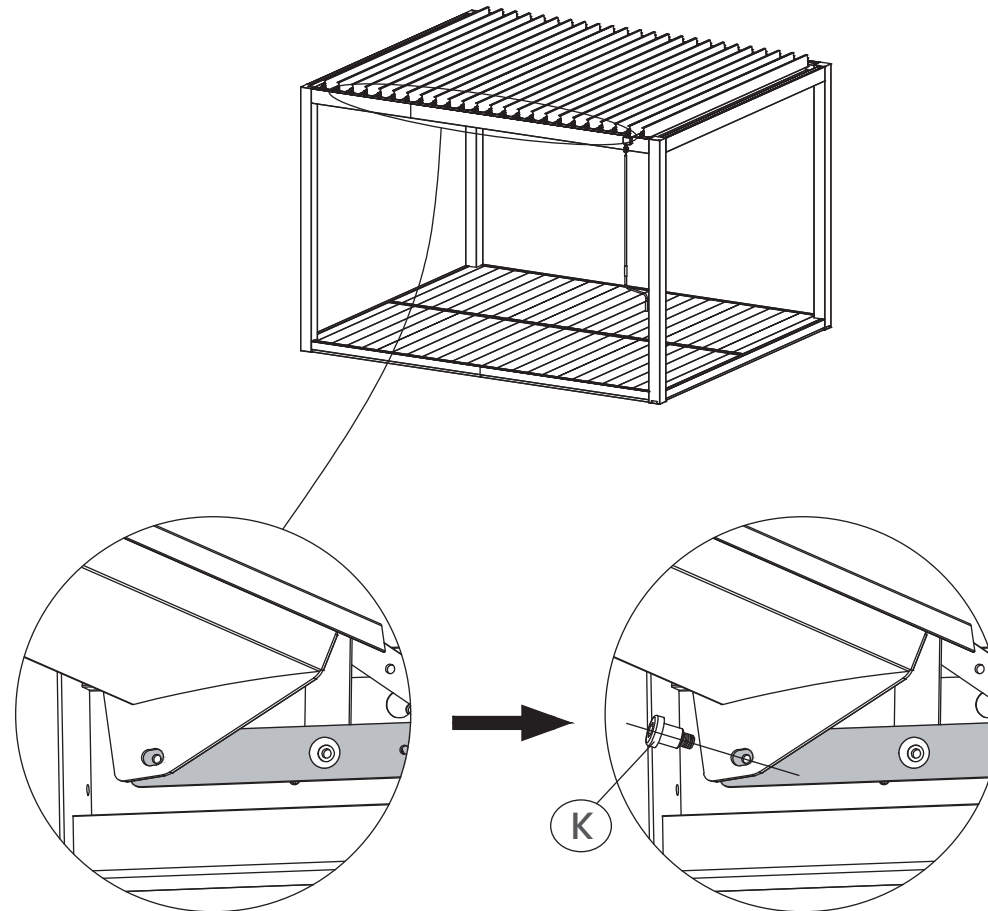

 Ø8.8x10xM6x5 K X22

54

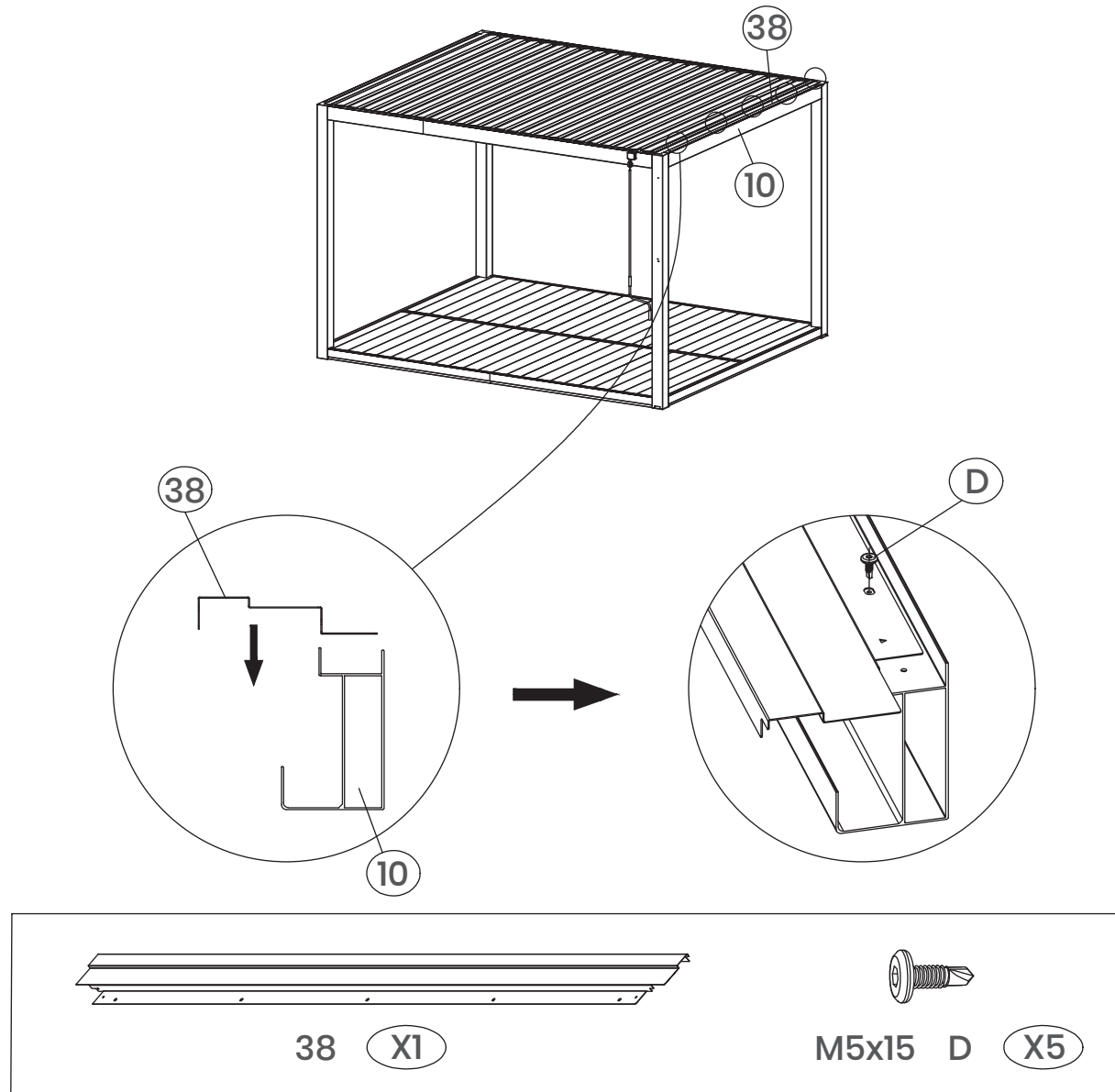

55

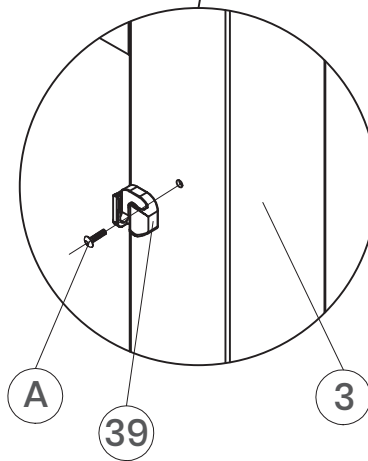
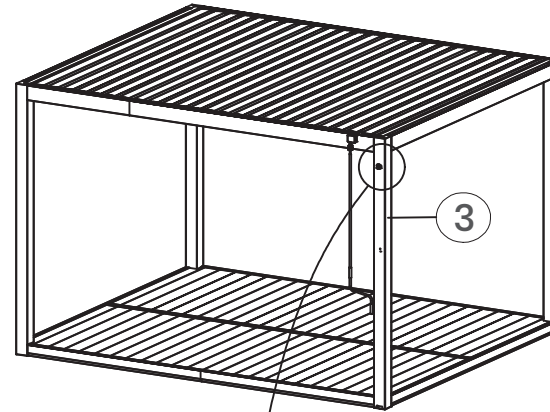

39 (X1)

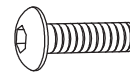

M6x15 A (X1)

56

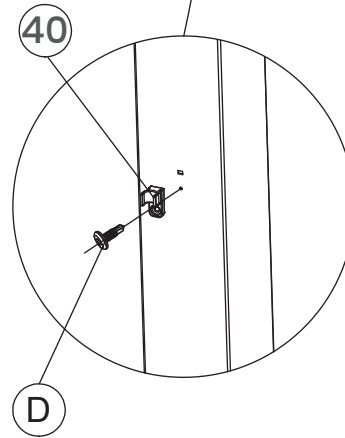
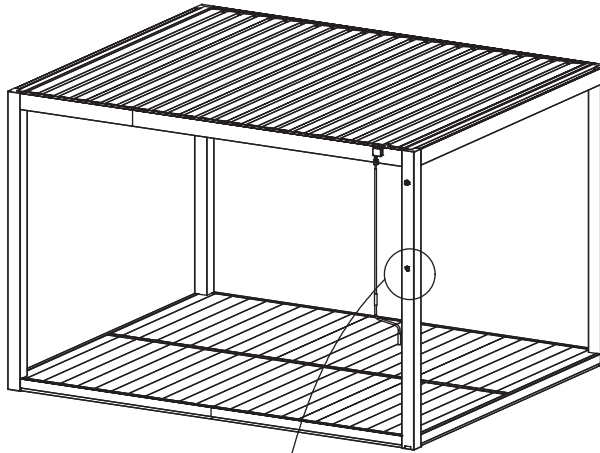

40 (X1)

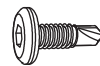

M5x15 D (X1)

# Structure Operation / Fonctionnement de la structure / Funcionamiento de la estructura

---

Note: When opening/closing the louvers, ensure the handle remains vertically positioned next to the post. Do not move the handle too far from the post. Turn the handle clockwise to open the louvers. Turn it counter-clockwise to close the louvers.

Remarque : Lors de l'ouverture ou de la fermeture des persiennes, veillez à ce que la poignée reste verticalement contre le montant. Ne l'éloignez pas trop. Tournez la poignée dans le sens horaire pour ouvrir les persiennes et dans le sens antihoraire pour les fermer.

Nota: Al abrir o cerrar las lamas, asegúrese de que la manija permanezca vertical junto al poste. No la aleje demasiado del poste. Gire la manija en sentido horario para abrir las lamas. Gírela en sentido antihorario para cerrarlas.

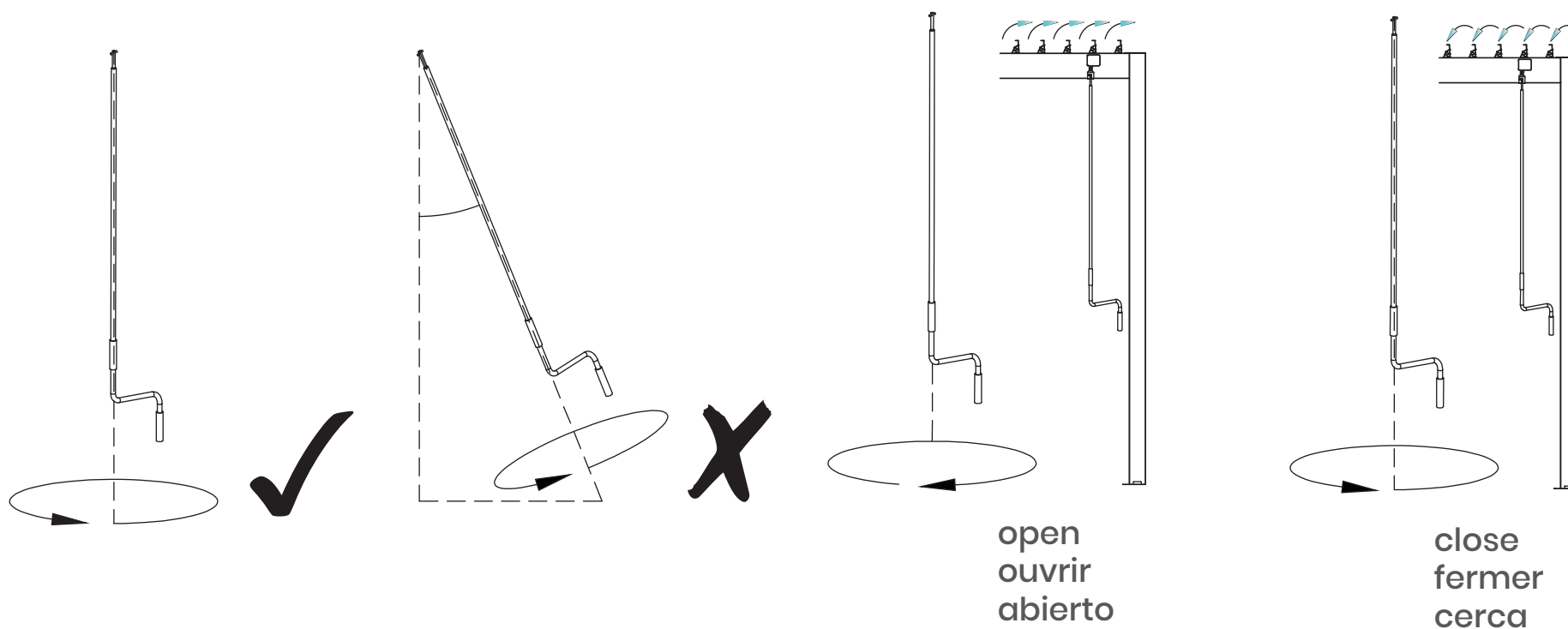

# SUNVILLA

Distributed by:  
Costco Wholesale Corporation  
P.O. Box 34535  
Seattle, WA 98124-1535  
USA  
1-800-774-2678  
[www.costco.com](http://www.costco.com)

Costco Wholesale UK Ltd /  
Costco Online UK Ltd  
Hartspring Lane  
Watford, Herts  
WD25 8JS  
United Kingdom  
01923 213113  
[www.costco.co.uk/contact](http://www.costco.co.uk/contact)

Costco Wholesale Japan Ltd.  
2 Kakuchi, 2 Gaiku, Kaneda-Nishi  
361 Urakura, Kisarazu shi  
Chiba, 292-0007 Japan  
0570-200-800  
[www.costco.co.jp](http://www.costco.co.jp)

Costco Wholesale Sweden AB  
Box 614  
114 11 Stockholm  
Sweden  
[www.costco.se/contact](http://www.costco.se/contact)

Costco Wholesale Canada Ltd.\*  
415 W. Hunt Club Road  
Ottawa, Ontario  
K2E 1C5, Canada  
1-800-463-3783  
[www.costco.ca](http://www.costco.ca)

\* faisant affaire au Québec sous  
le nom les Entrepôts Costco

Costco Wholesale Spain S.L.U.  
Polígono Empresarial Los Gavilanes  
C/ Agustín de Betancourt, 17  
28906 Getafe (Madrid) España  
NIF: B86509460  
900 111 155  
[www.costco.es/contact](http://www.costco.es/contact)

Costco Wholesale Korea, Ltd.  
40, Iljik-ro  
Gwangmyeong-si  
Gyeonggi-do, 14347, Korea  
1899-9900  
[www.costco.co.kr](http://www.costco.co.kr)

Importado por:  
Importadora Primex S.A. de C.V.  
Blvd. Magnocentro No. 4  
San Fernando La Herradura  
Huixquilucan, Estado de México  
C.P. 52765  
RFC: IPR-930907-S70  
(55)-5246-5500  
[www.costco.com.mx](http://www.costco.com.mx)

Costco Wholesale Iceland ehf.  
Kauptún 3-7, 210 Gardabaer  
Iceland  
[www.costco.is/contact](http://www.costco.is/contact)

Costco Wholesale New Zealand Limited  
2 Gunton Drive  
Westgate  
Auckland 0814  
New Zealand  
[www.costco.co.nz](http://www.costco.co.nz)

Costco Wholesale Australia Pty Ltd  
17-21 Parramatta Road  
Lidcombe NSW 2141  
Australia  
[www.costco.com.au](http://www.costco.com.au)

Costco France  
1 avenue de Bréhat  
91140 Villebon-sur-Yvette  
France  
01 80 45 01 10  
[www.costco.fr/contact](http://www.costco.fr/contact)

Costco (China) Investment Co., Ltd.  
Room 01 Mezzanine  
No. 5178, Kang Xin Highway  
Pudong New District  
Shanghai  
China 201315  
+86-21-6257-7065

MADE IN CHINA  
FABRIQUÉ EN CHINE  
HECHO EN CHINA