

Multi-Purpose Adjustable Louvered Pergola

ITM. / ART. # 1857675

IMPORTANT, RETAIN FOR FUTURE REFERENCE: READ CAREFULLY
THIS ITEM IS INTENDED FOR OUTDOOR DOMESTIC USE ONLY.
NOT FOR COMMERCIAL USE.

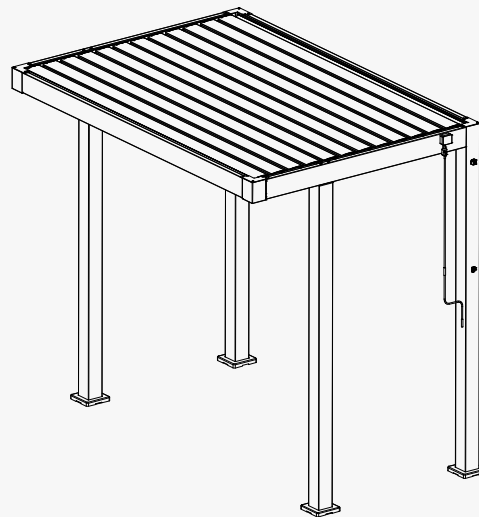

Questions, problems, missing parts?

Before returning to your retailer, call our Customer Service Department at 1-888-690-9800 (8:00 am - 5:00 pm PT, Monday - Friday, English and Spanish) or email us at service@sunvilla.com.

Preparation

Before beginning to assemble this product, make sure all parts are present. Compare parts with package contents list and hardware contents list. If any parts are missing or damaged, do not attempt to assemble this product. Stop and call our Customer Service Center.

Estimated Assembly Time: 120 minutes (3 people). Tools Required for Assembly: Hex Wrench, Wrench, Phillips Screwdriver (included).

⚠ Safety Information

Please read and understand this entire manual before attempting to assemble or install the product. It should not be used as a toy or tool. Children should not engage in the operation, assembly, removal, or disassembly of the product.

Table of Contents / Table des matières / Tabla de Contenido

Care & Maintenance	3
Nettoyage et entretien	6
Instrucciones de cuidado y mantenimiento	9
<hr/>	
Warranty	4
Garantie	7
Garantía	10
<hr/>	
Structure Parts List	
Liste des pièces	11
Lista de piezas	
<hr/>	
Structure Assembly	
Montage	14
Instrucciones de ensamble	
<hr/>	

SCAN FOR **BILT** 3D INSTRUCTIONS



POWERED BY **BILT INTELLIGENT INSTRUCTIONS***

Care and Maintenance

Frame

Hand wash with mild soap and rinse thoroughly with water. Dry with a soft cloth.

Do not use abrasive cleaners or scrub too rough as it may mar the surface.

During snowy conditions or when snow is expected, ensure the louvers are fully open and kept vertical to prevent damage. If there is debris or leaves on the top louver, promptly clean them to prevent issues with closing properly or failure to close.

Warranty

2 YEAR LIMITED WARRANTY*

This product is covered under a manufacturer's 2 year warranty from the date of purchase against defects in materials and workmanship. This warranty does not cover damage due to neglect, abuse, or weather related damage.

AUSTRALIA: Our goods come with guarantees that cannot be excluded under the Australian Consumer Law. You are entitled to a replacement or refund for a major failure and for compensation for any other reasonably foreseeable loss or damage. You are also entitled to have the goods repaired or replaced if the goods fail to be of acceptable quality and the failure does not amount to a major failure.

For warranty disclosure, email us at: service@sunvilla.com or chat with us at <https://sunvilla.com>.

Pergola à persiennes polyvalente ajustable

ITM. / ART. # 1857675

IMPORTANT, À CONSERVER POUR DE FUTURS BESOINS DE RÉFÉRENCE : À LIRE SOIGNEUSEMENT

CET ARTICLE EST DESTINÉ À UN USAGE DOMESTIQUE EXTÉRIEUR UNIQUEMENT.
NON CONÇU POUR UNE UTILISATION COMMERCIALE.

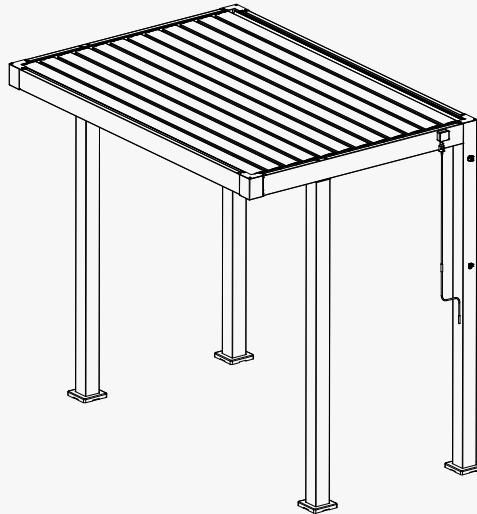

Questions ? Pièces manquantes ?

Avant de retourner chez le détaillant, communiquer avec le service à la clientèle au 1-888-690-9800, en semaine, entre 8 h et 17 h (heure du Pacifique) ou entre 11 h et 20 h (heure de l'Est), ou écrire à service@sunvilla.com. Service en anglais et en espagnol.

Préparation

Avant de commencer le montage, vérifier qu'il ne manque aucune pièce. Comparer le contenu de l'emballage avec la liste des pièces et de la quincaillerie. Si une pièce manque ou est brisée, ne pas assembler le produit; appeler le service à la clientèle.

Temps d'assemblage estimé : 120 minutes (3 personnes). Outils requis : Clé hexagonale, Clé, Tournevis à pointe cruciforme (comprise).

⚠ Consignes de sécurité

Lire attentivement le présent guide avant de commencer l'assemblage du produit. Ce n'est ni un jouet ni un outil. Les enfants ne doivent pas actionner, assembler, déplacer ou démonter le produit.

Entretien et maintenance

Cadre des Pergola

Nettoyer à la main avec une solution de savon doux et d'eau, puis rincer à fond. Sécher avec un linge doux.

Ne pas utiliser de nettoyants abrasifs ou frotter trop vigoureusement, car cela pourrait abîmer la surface.

Lorsqu'il neige ou qu'une chute de neige est attendue, s'assurer que les persiennes sont complètement ouvertes et en position verticale afin d'éviter tout dommage. Si des débris ou des feuilles tombent sur les persiennes supérieures, les nettoyer rapidement afin d'éviter les problèmes de fermeture.

Garantie

GARANTIE LIMITÉE DE 2 ANS*

Ce produit est couvert par une garantie du fabricant de 2 ans à partir de la date d'achat, qui couvre les défauts de matériaux et de fabrication. Cette garantie exclut les dommages causés par la négligence, l'utilisation abusive ou les conditions climatiques.

AUSTRALIE : Nos articles sont offerts avec des garanties qui ne peuvent connaître d'exclusions au regard de la loi australienne sur la protection des consommateurs. Vous avez droit au remplacement ou au remboursement en cas de défaillance majeure de votre article ainsi qu'à une compensation en cas de perte ou de dommage prévisible. Vous avez aussi droit à la réparation ou au remplacement de l'article s'il n'est pas d'une qualité acceptable et que la défaillance n'est pas majeure.

Pour obtenir la garantie, communiquer avec nous par courriel à service@sunvilla.com, ou par clavardage sur <https://sunvilla.com>.

Pérgola de rejillas ajustables multiusos

ITM. / ART. # 1857675

**IMPORTANTE: CONSERVE PARA FUTURA REFERENCIA. LEA
CUIDADOSAMENTE**

**ESTE ARTÍCULO ES PARA USO DOMÉSTICO EN EXTERIORES SOLAMENTE.
NO ES PARA USO COMERCIAL.**

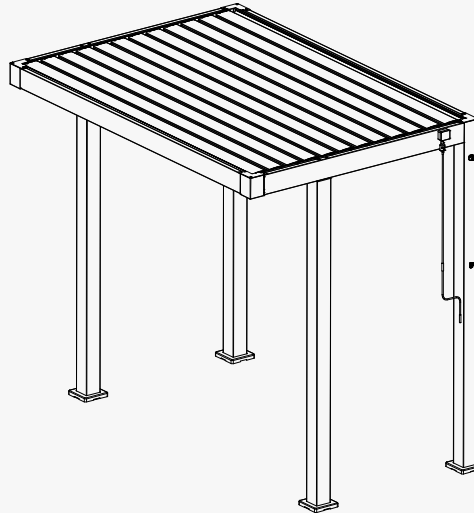

¿Preguntas, problemas o piezas faltantes?

Antes de regresar el producto a la tienda, llame a nuestro departamento de Servicio al Cliente al 1-888-690-9800 o envíe un correo electrónico a service@sunvilla.com, de lunes a viernes, de 8:00 am a 5:00 pm, hora del Pacífico de E.U.A o de 11:00 am a 8:00 pm, hora del Este de E.U.A.

Inglés y español.

PREPARACIÓN

Antes de comenzar a ensamblar este producto, asegúrese que todas las piezas estén completas. Compare las piezas con el listado de contenido de piezas y de herramientas del empaque. No intente ensamblar el producto si faltase alguna pieza o si estuviera dañada. Si así fuera, no continúe y llame a nuestro centro de servicio al cliente. Tiempo estimado de ensamble: 120 minutos (3 personas). Herramientas requeridas para el ensamble: Llave inglesa, Llave hexagonal, Destornillador Phillips (incluido).

⚠ INFORMACIÓN DE SEGURIDAD

Por favor lea con atención este manual completo antes de ensamblar o instalar el producto. Los niños no deben participar en la operación, el ensamblaje, remoción o desmontaje del producto.

Cuidados y mantenimiento

Almacén de la Pérgola

Lave a mano con jabón suave y enjuague bien con agua. Seque con un paño suave.

No use limpiadores abrasivos ni talle muy fuerte ya que esto puede dañar la superficie.

En condiciones de nieve o cuando se espere nevada, asegúrese de que las rejillas estén completamente abiertas y se mantengan verticales para evitar daños. Si hay residuos u hojas en la rejilla superior, límpielas rápidamente para evitar problemas de cierre o evitar que se cierren incorrectamente.

Garantía

2 AÑOS DE GARANTÍA LIMITADA*

Este producto está cubierto por una garantía del fabricante de 2 años a partir de la fecha de compra contra defectos de materiales y mano de obra. Esta garantía no cubre daños debidos a negligencia, abuso o daños relacionados con el clima.

AUSTRALIA: Nuestros productos cuentan con garantías que no se pueden excluir bajo las Leyes del Consumidor de Australia. Usted tiene derecho a un cambio o devolución en caso de un fallo importante y a una compensación por cualquier otra pérdida o daño razonablemente previsible. También tiene derecho a la reparación o reemplazo de los bienes, si éstos no cumplen con una calidad aceptable y el fallo no constituye un fallo importante.

Para obtener información sobre la garantía, envíenos un correo electrónico a service@sunvilla.com o chatee con nosotros en <https://sunvilla.com>.

Structure Parts List / Liste des pièces / Lista de piezas de la estructura

⚠ WARNING: Perform all assembly steps on a flat, soft, non-abrasive surface to avoid scratching the finish.

⚠ AVERTISSEMENT : Pour éviter d'endommager votre nouveau parapluie, veuillez utiliser le carton ou un autre surface douce telle qu'un tapis comme surface de travail pour éviter d'endommager le produit lors de l'assemblage.

⚠ WARNING: Para evitar daños a su nuevo paraguas, utilice la caja de cartón u otra superficie blanda, como una alfombra, como superficie de trabajo para evitar daños al producto durante el montaje.

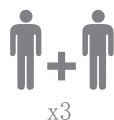

Estimated Assembly Time: 120 minutes
Recommended: 3 people
Temps de montage estimé : 120 minutes
Recommandation : 3 personnes
Tiempo estimado de ensamble duración: 120 minutos
Recomendado: 3 personas



Hand tighten
Serrer à la main
Apretar a mano









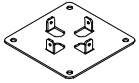
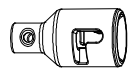

Fully tighten
Serrer complètement
Apretar completamente

	PARTS LIST LISTE DES PIÈCES LISTA DE PIEZAS	DESCRIPTION DESCRIPTION DESCRIPCIÓN	QTY QTÉ CANT	Carton# No de boîte Cartón
1		Post 1 Poteau 1 Poste 1	1	1
2		Post 2 Poteau 2 Poste 2	1	1
3		Post 3 Poteau 3 Poste 3	2	1
4		Right Beam Poutre droite Viga Derecha	1	1
5		Left Beam Poutre gauche Viga izquierda	1	1

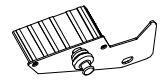
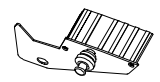
	PARTS LIST LISTE DES PIÈCES LISTA DE PIEZAS	DESCRIPTION DESCRIPTION DESCRIPCIÓN	QTY QTÉ CANT	Carton# No de boîte Cartón
6		Front/back beam Poutres avant et arrière Viga delantera/trasera	2	1
7		Louver Persiennes Panel de rejillas	12	2
8		Beam Connector Connecteur de poutres Conector de viga	2	1
9		Sealing of Post Capuchon de poteau Sellado del poste	4	1
10		Foot Cover Couvre-pied Tapa de pie	4	1



IMPORTANT, RETAIN FOR FUTURE REFERENCE: READ CAREFULLY
IMPORTANT, À CONSERVER POUR DE FUTURS BESOINS DE RÉFÉRENCE : À LIRE SOIGNEUSEMENT
IMPORTANTE: CONSERVE PARA FUTURA REFERENCIA. LEA CUIDADOSAMENTE





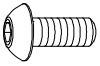
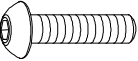
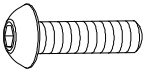
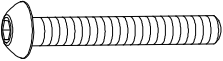

Structure Parts List / Liste des pièces / Lista de piezas de la estructura

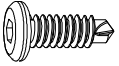
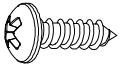
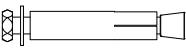
	PARTS LIST LISTE DES PIÈCES LISTA DE PIEZAS	DESCRIPTION DESCRIPTION DESCRIPCIÓN	QTY QTÉ CANT	Carton# No de boîte Cartón
11		Foot Plate 1 Plaque d'assise 1 Placa de pie 1	2	1
12		Turbine Turbine Turbina	1	1
13		Handle Manivelle Asa	1	1
14		Right Louver Connector Connecteur de persienne (droite) Conector rejilla derecha	12	1
15		Left Louver Connector Connecteur de persienne (gauche) Conector rejilla izquierda	12	1
16		Fastening Piece 1 Attache 1 Pieza de fijación 1	24+2	1
17		Foot Plate 2 Plaque d'assise 2 Placa de pie 2	2	1
18		Handle Storage Attache de rangement pour la manivelle Almacenamiento del asa	1	1
19		Handle Bracket Insertion de la manivelle Soporte del asa	1	1
20		Fastening Piece 2 Attache 2 Pieza de fijación 2	12+2	1

IMPORTANT, RETAIN FOR FUTURE REFERENCE: READ CAREFULLY
IMPORTANT, À CONSERVER POUR DE FUTURS BESOINS DE RÉFÉRENCE : À LIRE SOIGNEUSEMENT
IMPORTANTE: CONSERVE PARA FUTURA REFERENCIA. LEA CUIDADOSAMENTE

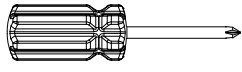
Structure Parts List / Liste des pièces / Lista de piezas de la estructura

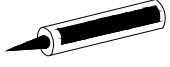
	PARTS LIST LISTE DES PIÈCES LISTA DE PIEZAS	DESCRIPTION DESCRIPTION DESCRIPCIÓN	QTY QTÉ CANT	Carton# No de boîte Cartón
A		M6x15 Bolt Boulon M6x15 Perno M6x15	20+2	1
B		M6x25 Bolt Boulon M6x25 Perno M6x25	8	1
C		M8x25 Bolt Boulon M8x25 Perno M8x25	2	1
D		M8x160 Bolt Boulon M8x160 Perno M8x160	4	1
E		M5x18 Bolt Boulon M5x18 Perno M5x18	1	1
F		M5x15 Bolt Boulon M5x15 Perno M5x15	2	1
G		ST4.2x12 Bolt Boulon ST4.2x12 Perno ST4.2x12	24+2	1
H		Anchor Ancrage Anclaje	14	1

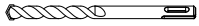
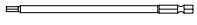
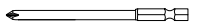
	PARTS LIST LISTE DES PIÈCES LISTA DE PIEZAS	DESCRIPTION DESCRIPTION DESCRIPCIÓN	QTY QTÉ CANT	Carton# No de boîte Cartón
J		4mm Hex Wrench Clé hexagonale de 4 mm Llave hexagonal 4 mm	2	1
K		Wrench Clé Llave inglesa	1	1
L		Phillips Screwdriver Tournevis à pointe cruciforme Destornillador Phillips	1	1
M		Wrench Clé Llave inglesa	1	1
		Silicone Neutral Glass Glue Colle à verre à base de silicone neutre Pegamento de silicona neutro para vidrio	1	not included non compris no incluido
		Cordless Drill Perceuse sans fil Taladro inalámbrico	1	not included non compris no incluido
		10mm Impact Drill Bit Embout de perçage à percussion de 10 mm Broca de impacto de 10 mm	1	not included non compris no incluido
		4mm Hex Socket Bit Douille tournevis hexagonal 4 mm Broca hexagonal de 4 mm	1	not included non compris no incluido
		Cross Bit Mors croisé Broca cruzada	1	not included non compris no incluido

IMPORTANT, RETAIN FOR FUTURE REFERENCE: READ CAREFULLY
IMPORTANT, À CONSERVER POUR DE FUTURS BESOINS DE RÉFÉRENCE : À LIRE SOIGNEUSEMENT
IMPORTANTE: CONSERVE PARA FUTURA REFERENCIA. LEA CUIDADOSAMENTE

Structure Assembly / Montage / Ensamble de la estructura

1

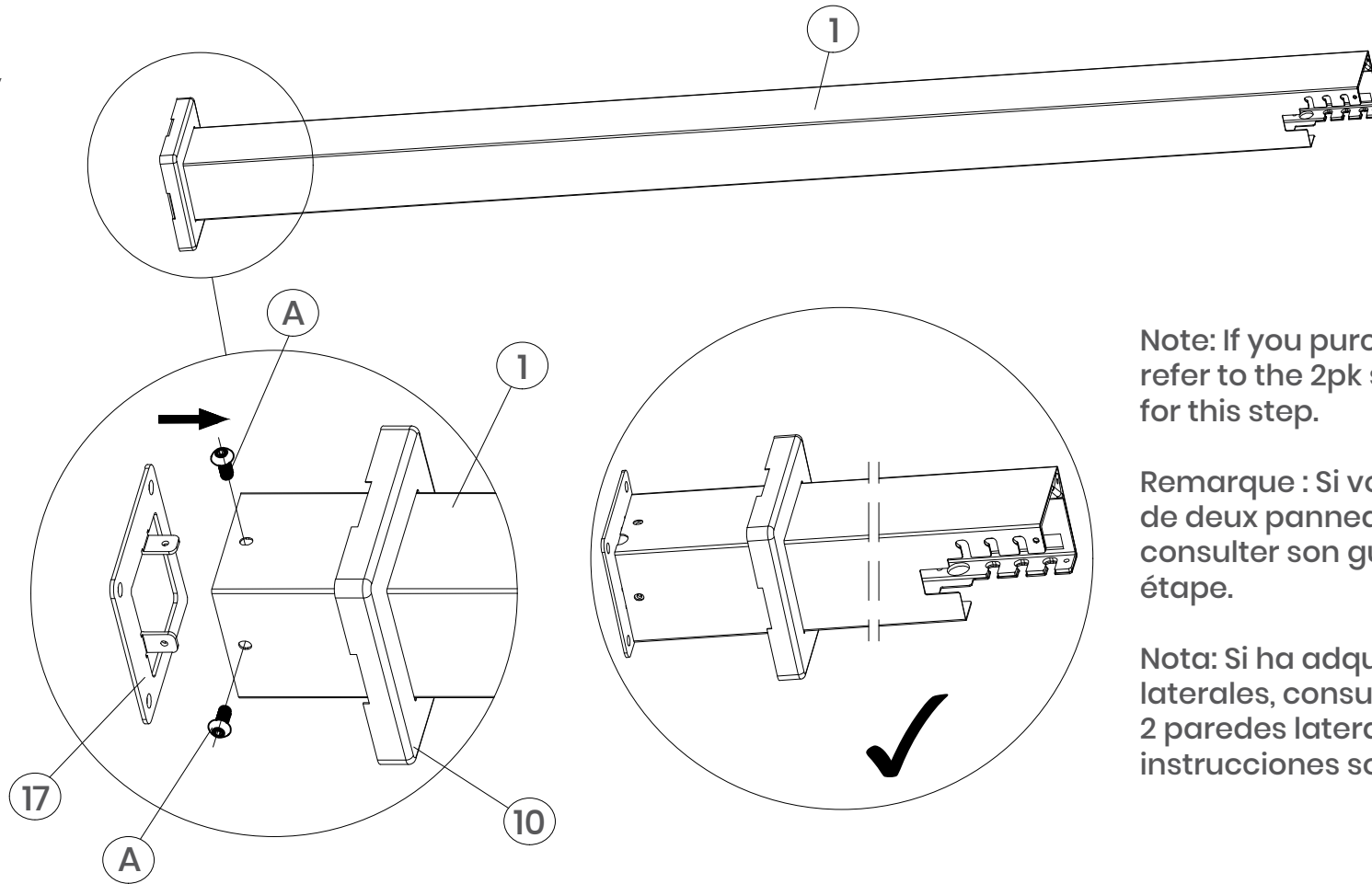

Note: If you purchased 2pk side wall, please refer to the 2pk side wall with track manual for this step.

Remarque : Si vous avez acheté le paquet de deux panneaux latéraux avec rail, consulter son guide d'installation à cette étape.



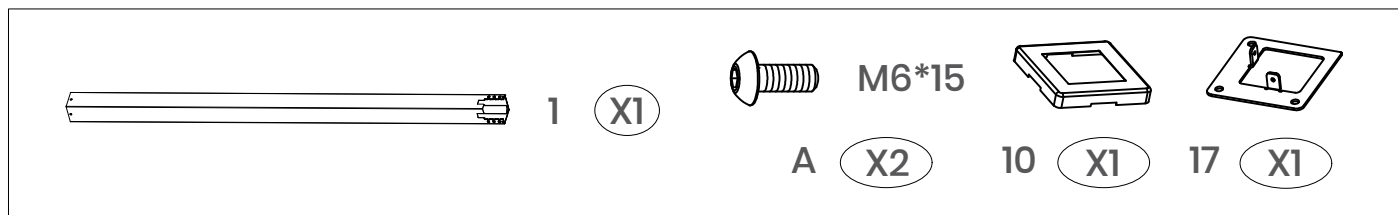

Nota: Si ha adquirido el juego de 2 paredes laterales, consulte el manual del juego de 2 paredes laterales con riel para obtener instrucciones sobre este paso.

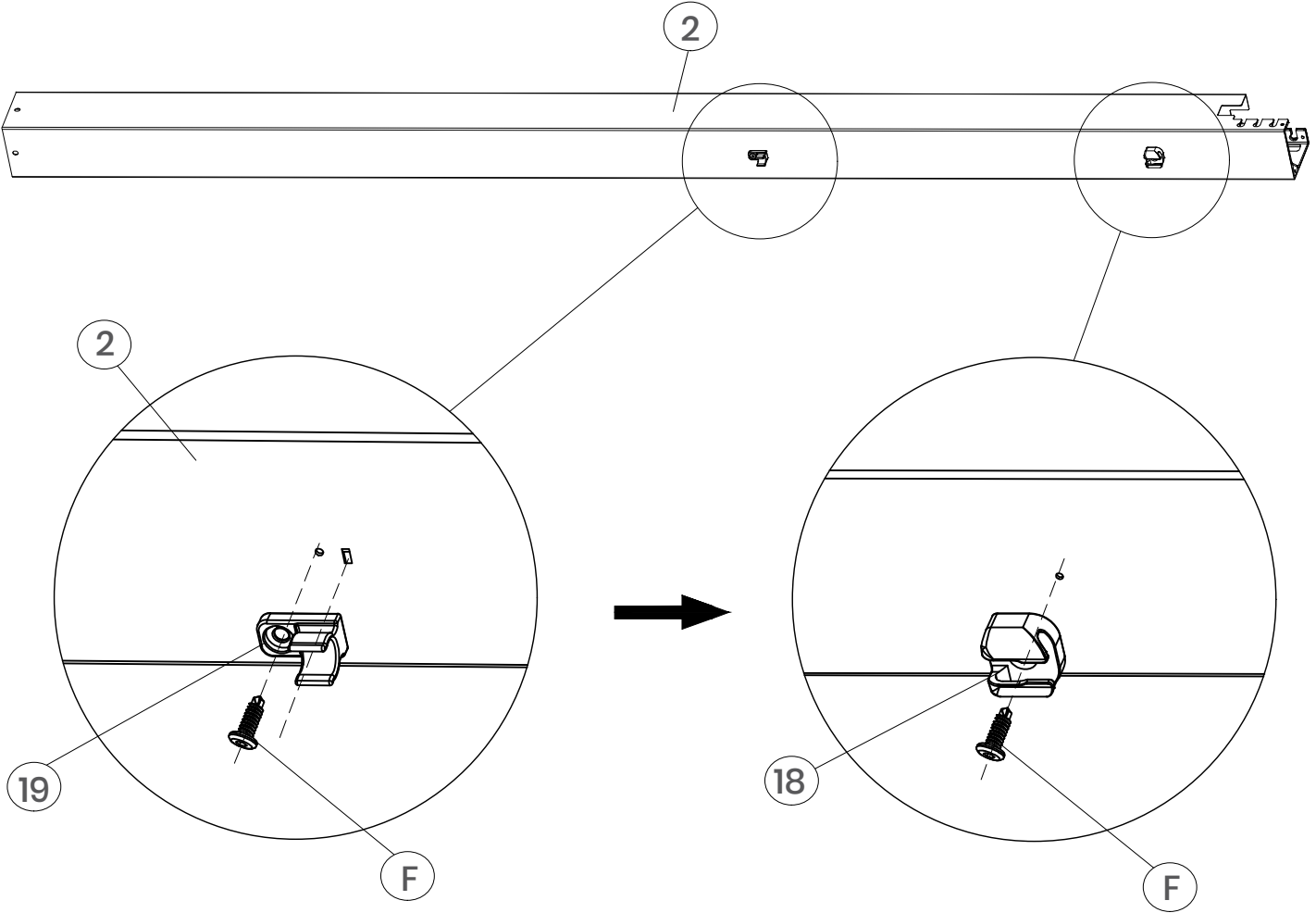

Structure Assembly / Montage / Ensamble de la estructura

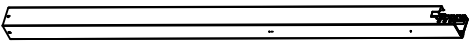
2



	2	(X1)		M5*15	F	(X2)		18	(X1)		19	(X1)
---	---	------	---	-------	---	------	---	----	------	---	----	------

Structure Assembly / Montage / Ensamble de la estructura

3

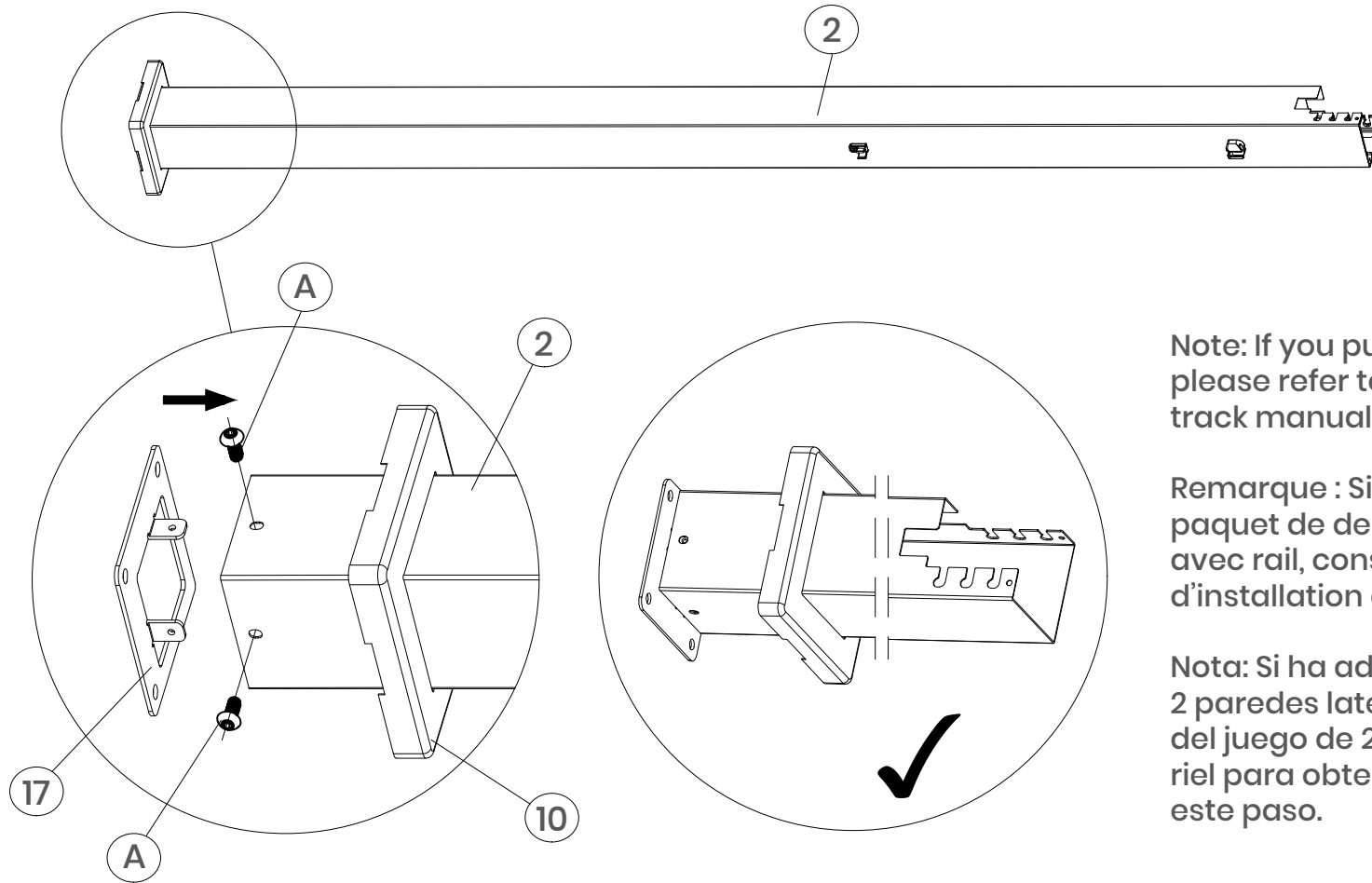

Note: If you purchased 2pk side wall, please refer to the 2pk side wall with track manual for this step.

Remarque : Si vous avez acheté le paquet de deux panneaux latéraux avec rail, consulter son guide d'installation à cette étape.

Nota: Si ha adquirido el juego de 2 paredes laterales, consulte el manual del juego de 2 paredes laterales con riel para obtener instrucciones sobre este paso.



A (X2)

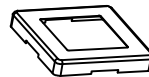

10 (X1)



17 (X1)

Structure Assembly / Montage / Ensamble de la estructura

4

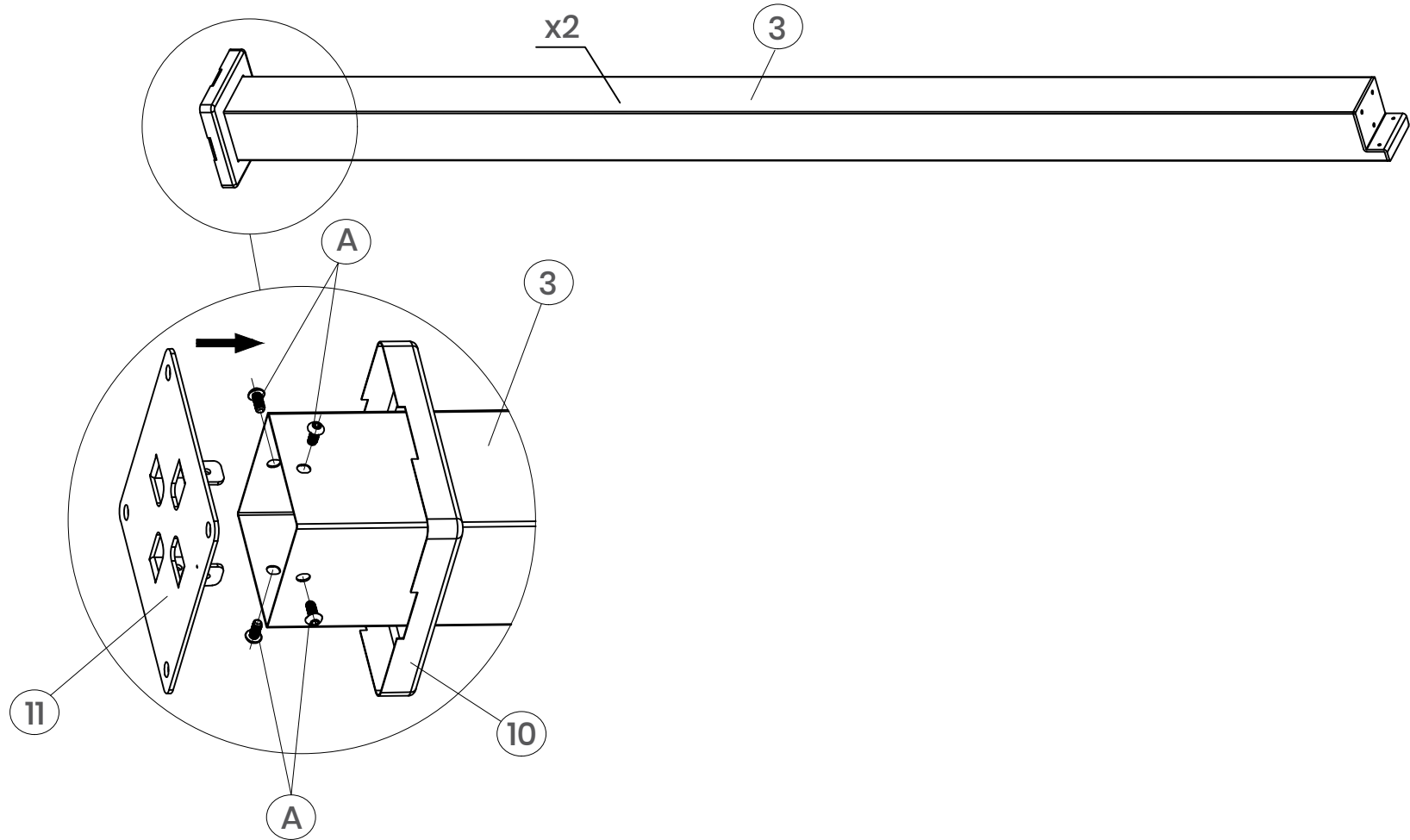

Structure Assembly / Montage / Ensamble de la estructura

5

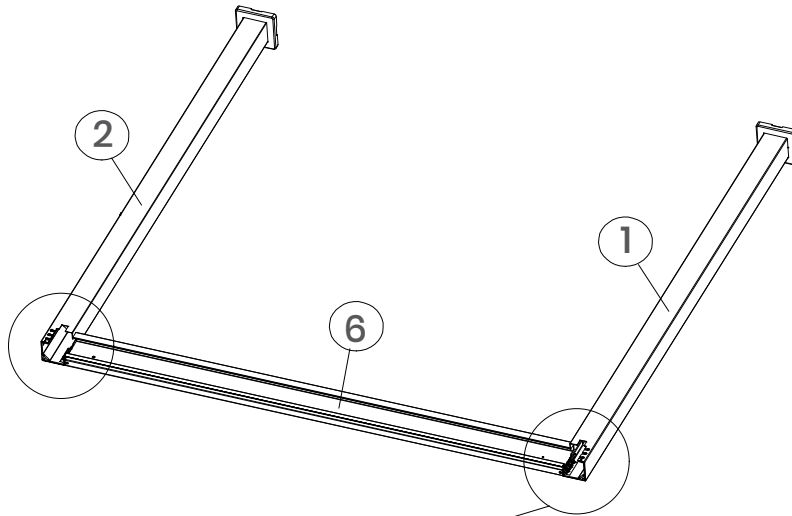

Note: Please tighten the bolts with the wrench.

Remarque : Serrer les vis avec la clé multifonctionnelle.

Nota: Por favor apriete los tornillos con la llave.

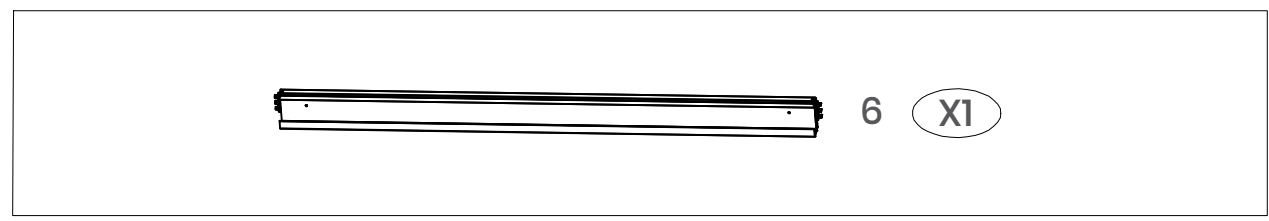
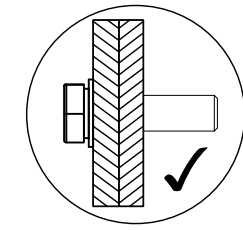
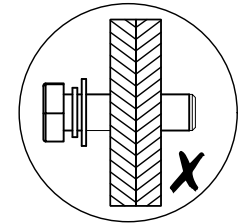
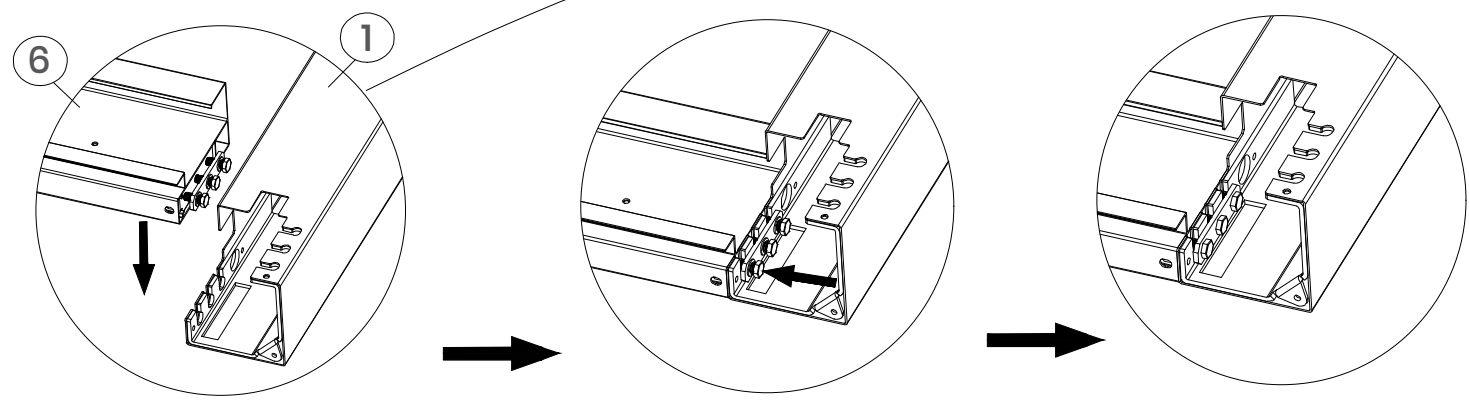

Structure Assembly / Montage / Ensamble de la estructura

6

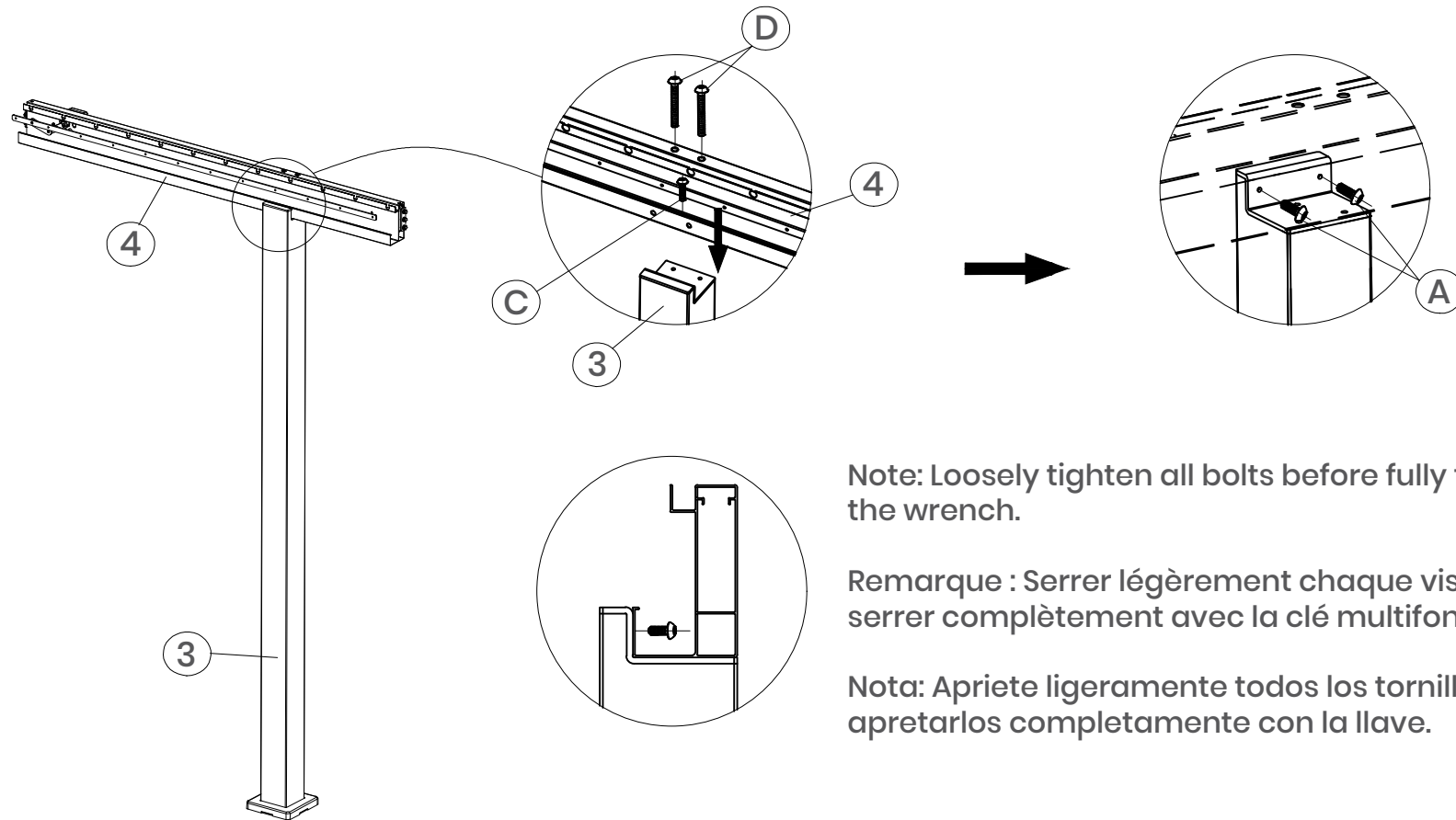

Note: Loosely tighten all bolts before fully tighten with the wrench.

Remarque : Serrer légèrement chaque vis avant de les serrer complètement avec la clé multifonctionnelle.

Nota: Apriete ligeramente todos los tornillos antes de apretarlos completamente con la llave.

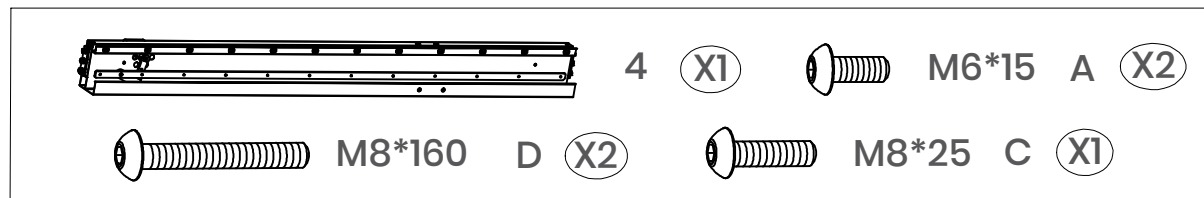

Structure Assembly / Montage / Ensamble de la estructura

7

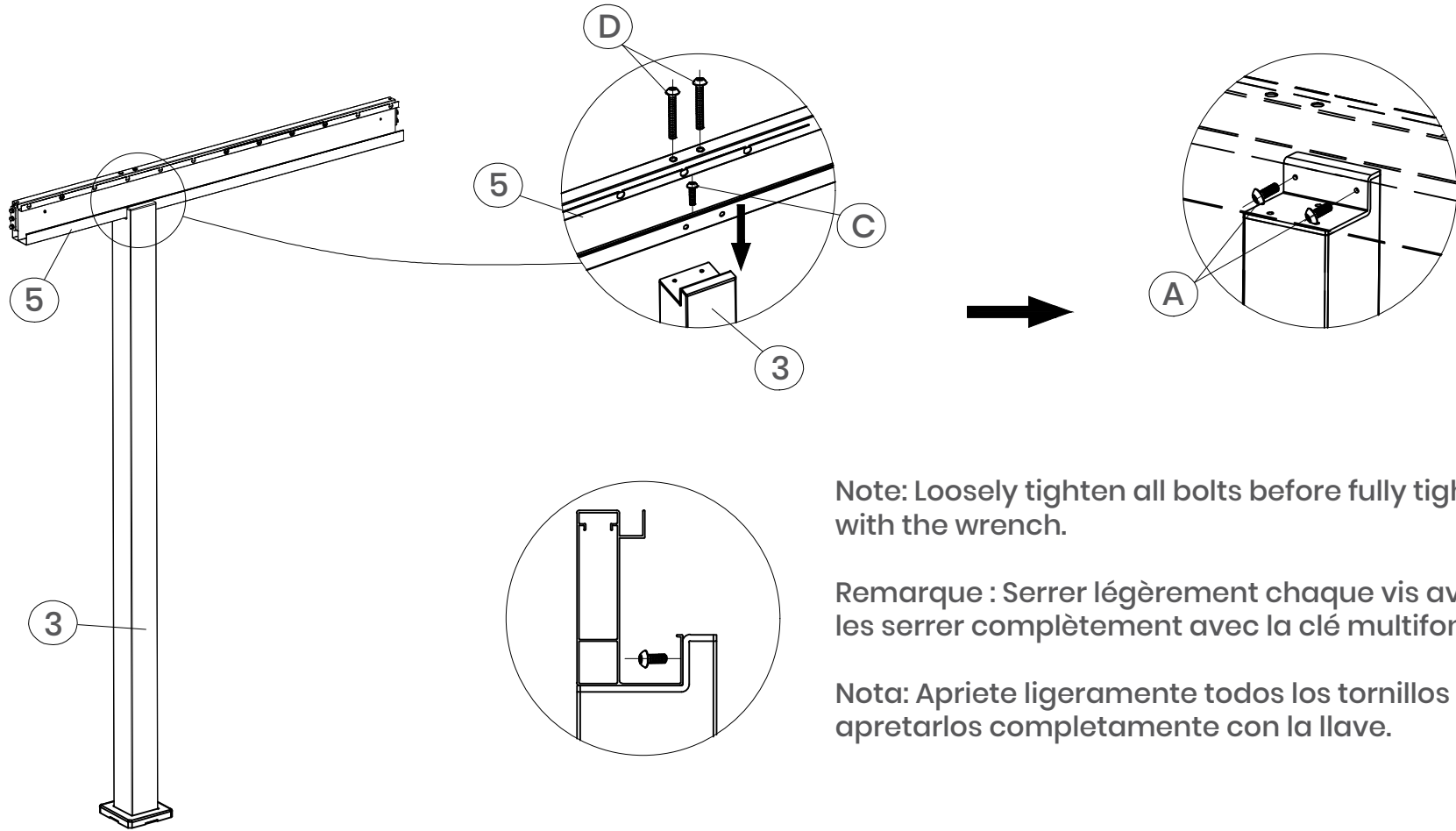

Note: Loosely tighten all bolts before fully tighten with the wrench.

Remarque : Serrer légèrement chaque vis avant de les serrer complètement avec la clé multifonctionnelle.

Nota: Apriete ligeramente todos los tornillos antes de apretarlos completamente con la llave.

	5	(X1)		M6*15	A	(X2)	
	M8*160	D	(X2)		M8*25	C	(X1)

Structure Assembly / Montage / Ensamble de la estructura

8

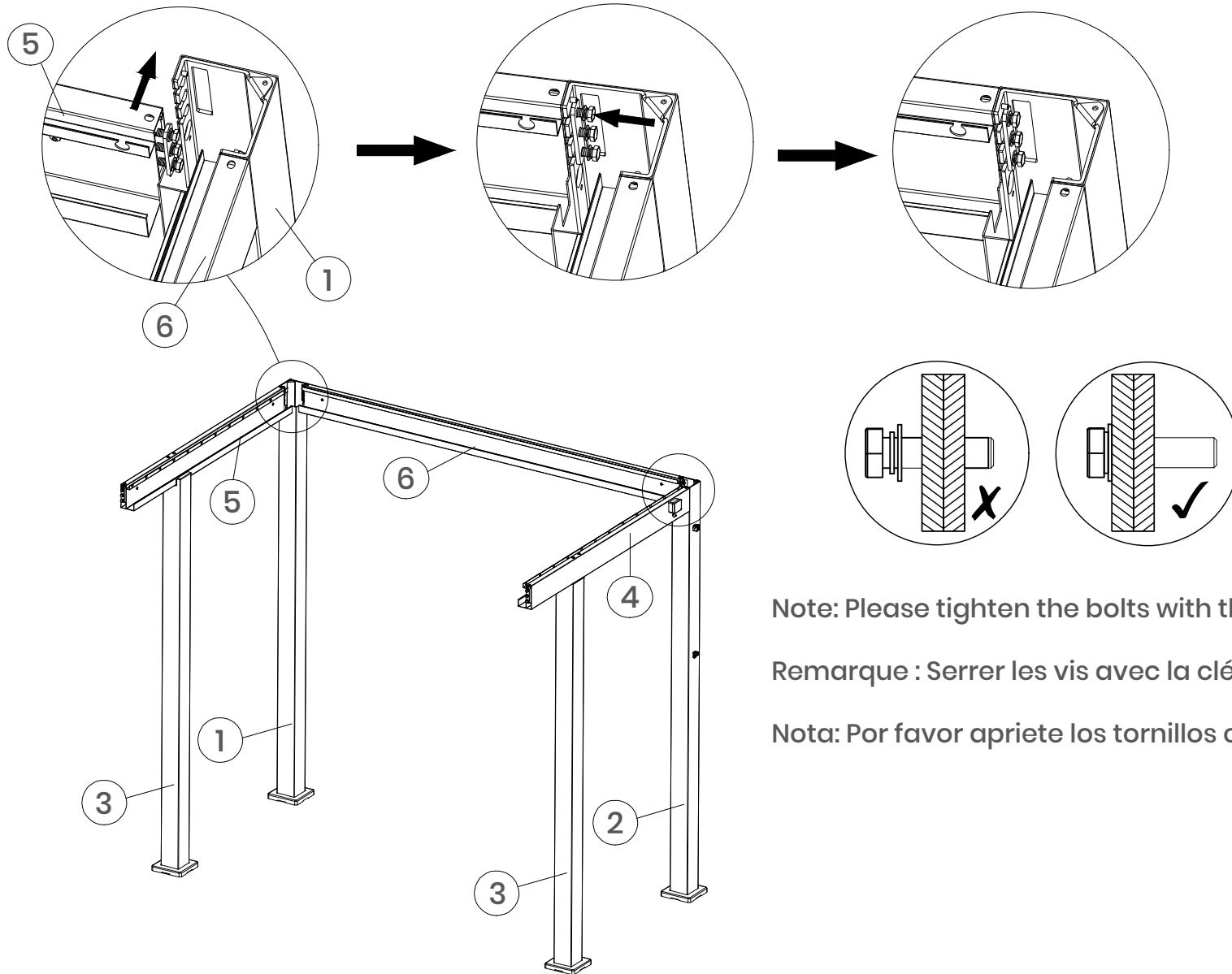

Note: Please tighten the bolts with the wrench.

Remarque : Serrer les vis avec la clé multifonctionnelle.

Nota: Por favor apriete los tornillos con la llave.

Structure Assembly / Montage / Ensamble de la estructura

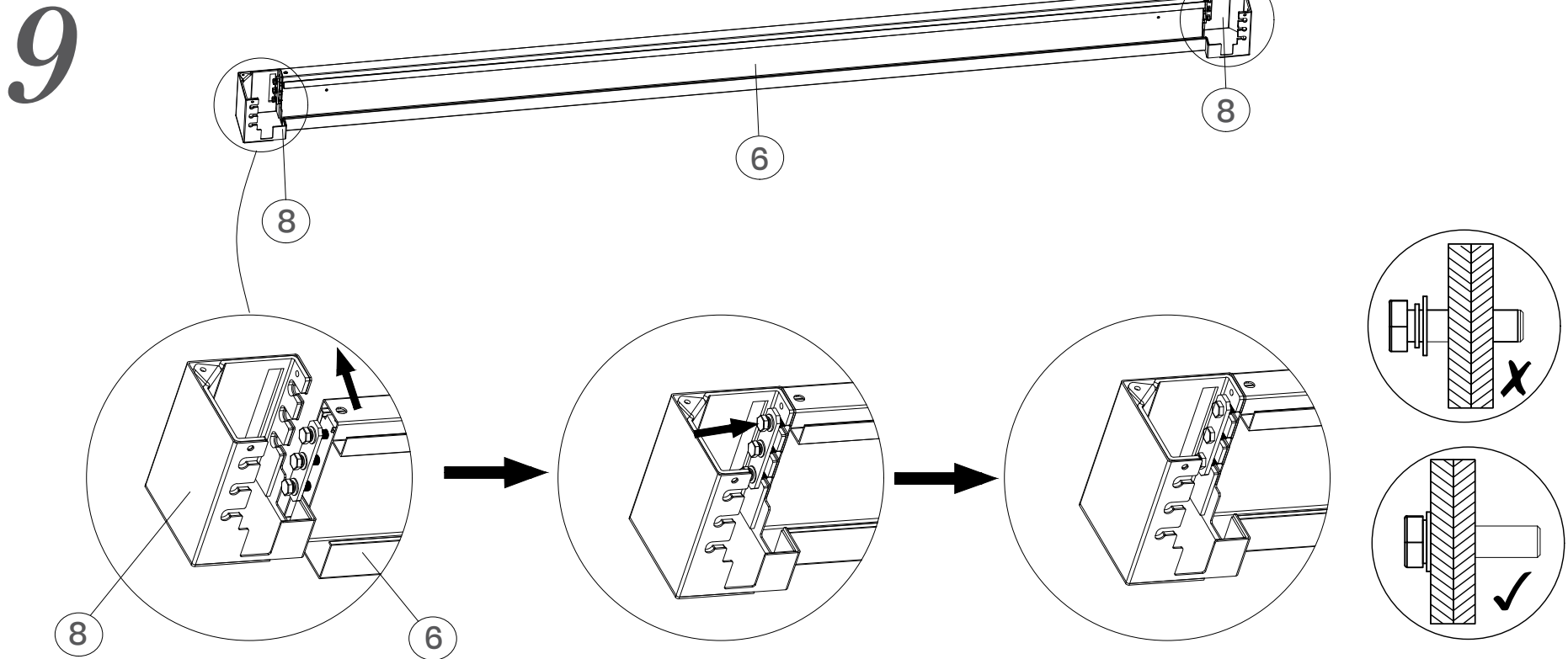

Note: Please tighten the bolts with the wrench.

Remarque : Serrer les vis avec la clé multifonctionnelle.

Nota: Por favor apriete los tornillos con la llave.

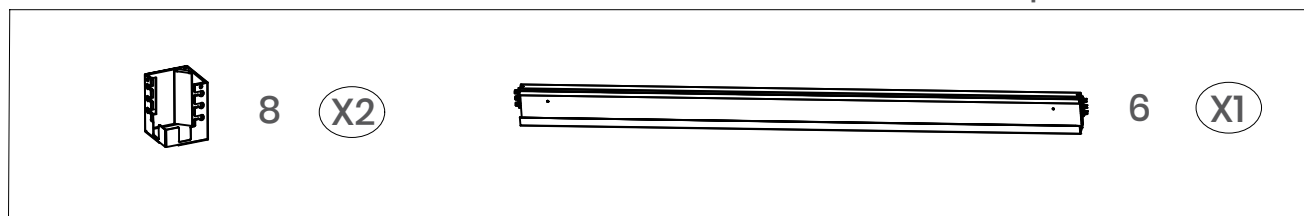

Structure Assembly / Montage / Ensamble de la estructura

10

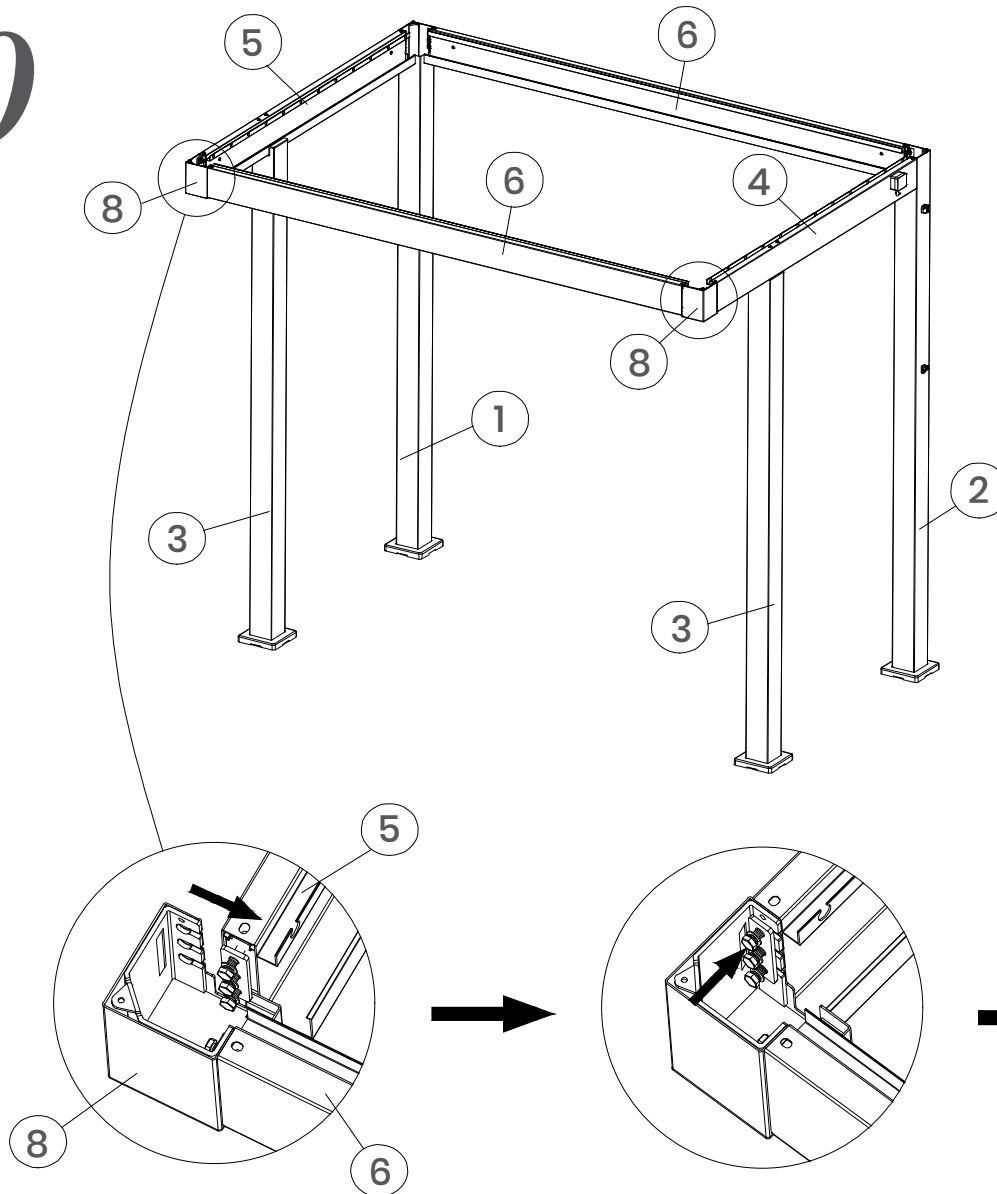

Note: Please tighten the bolts with the wrench.

Remarque : Serrer les vis avec la clé multifonctionnelle.

Nota: Por favor apriete los tornillos con la llave.

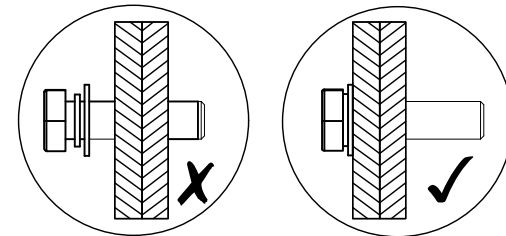

Structure Assembly / Montage / Ensamble de la estructura

11

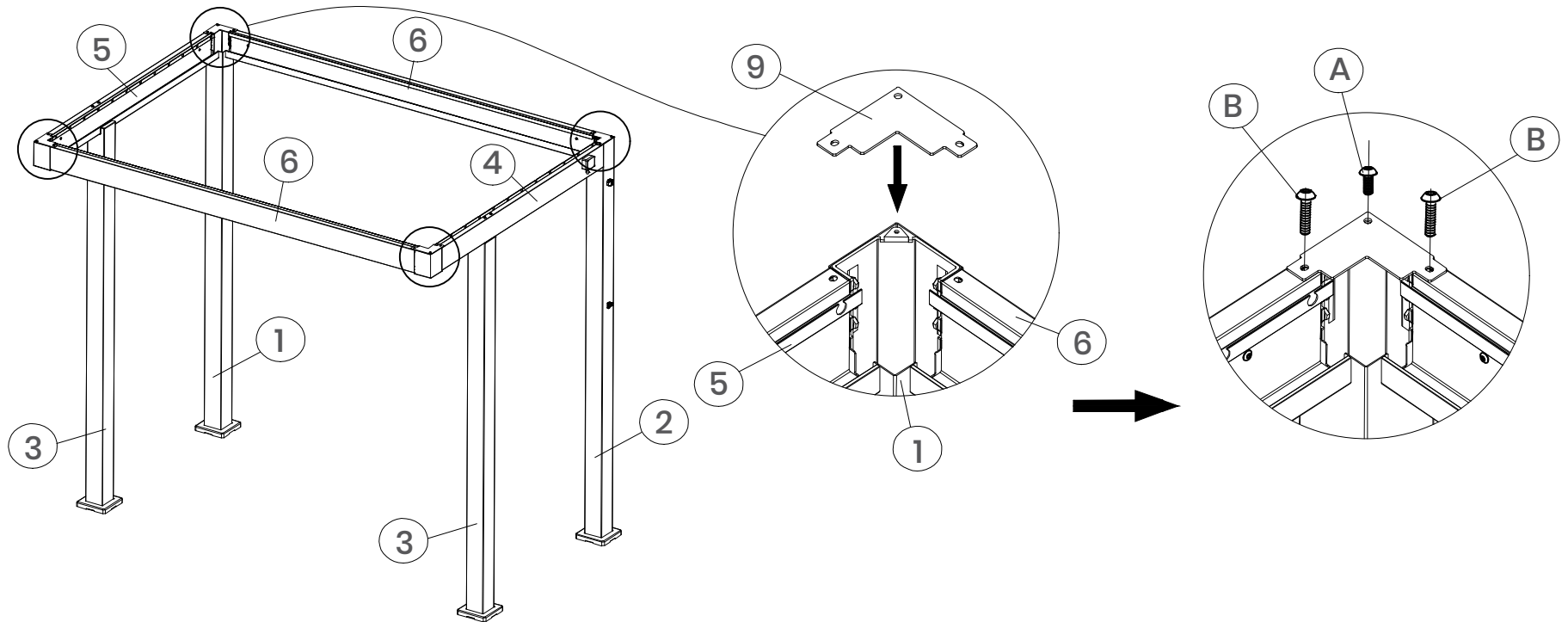

Note: Loosely tighten all bolts before fully tighten with the wrench.

Remarque : Serrer légèrement chaque vis avant de les serrer complètement avec la clé multifonctionnelle.

Nota: Apriete ligeramente todos los tornillos antes de apretarlos completamente con la llave.



12

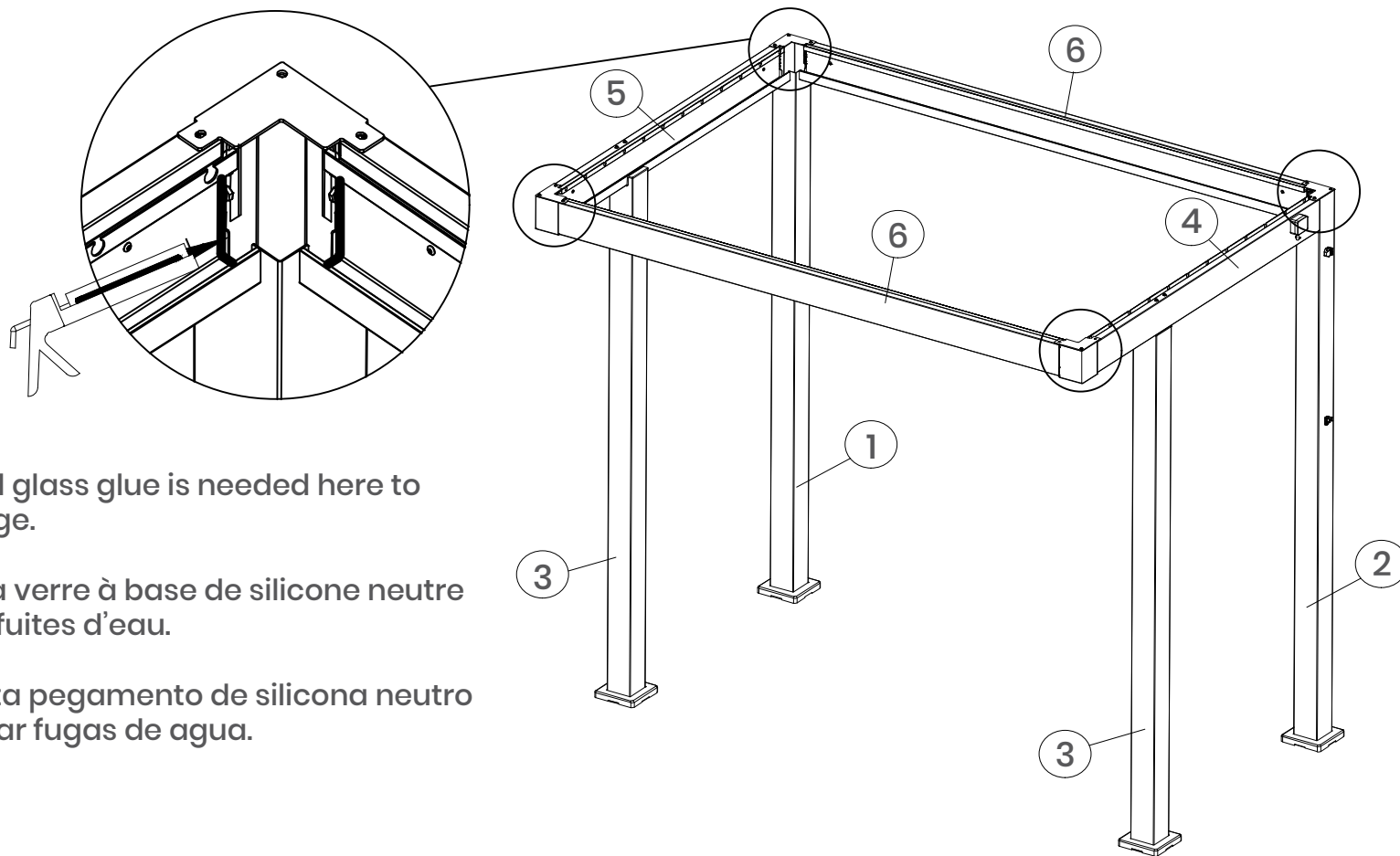

Note: Silicone neutral glass glue is needed here to prevent water leakage.

Remarque : La colle à verre à base de silicone neutre sert à empêcher les fuites d'eau.

Nota: Aquí se necesita pegamento de silicona neutro para vidrio para evitar fugas de agua.



13

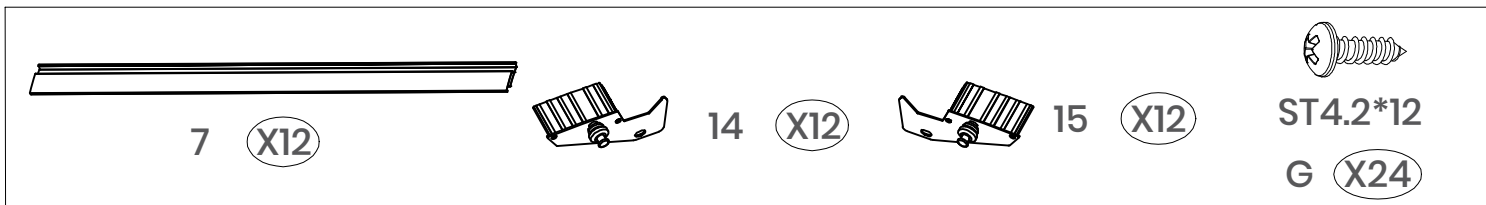
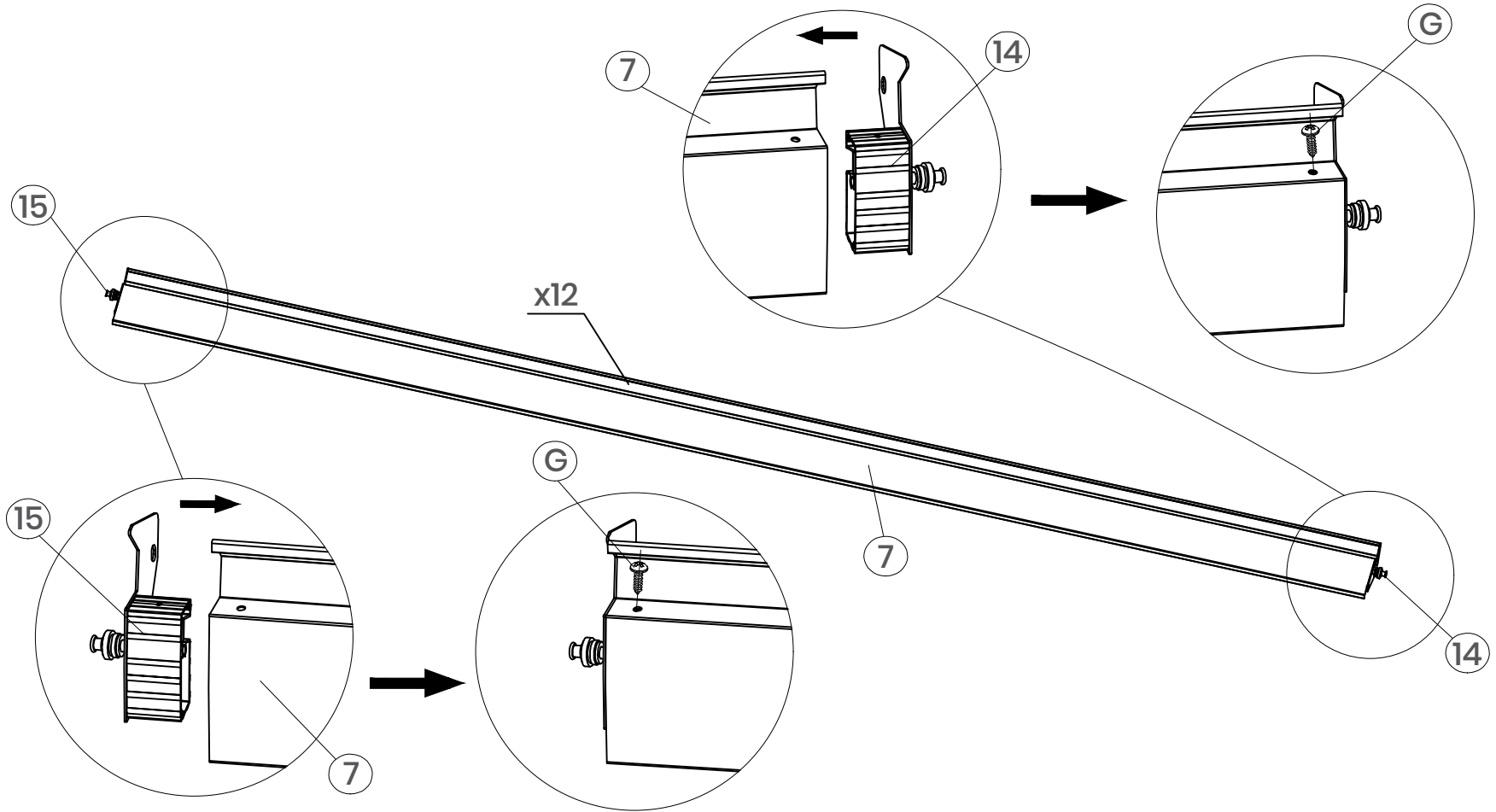

14

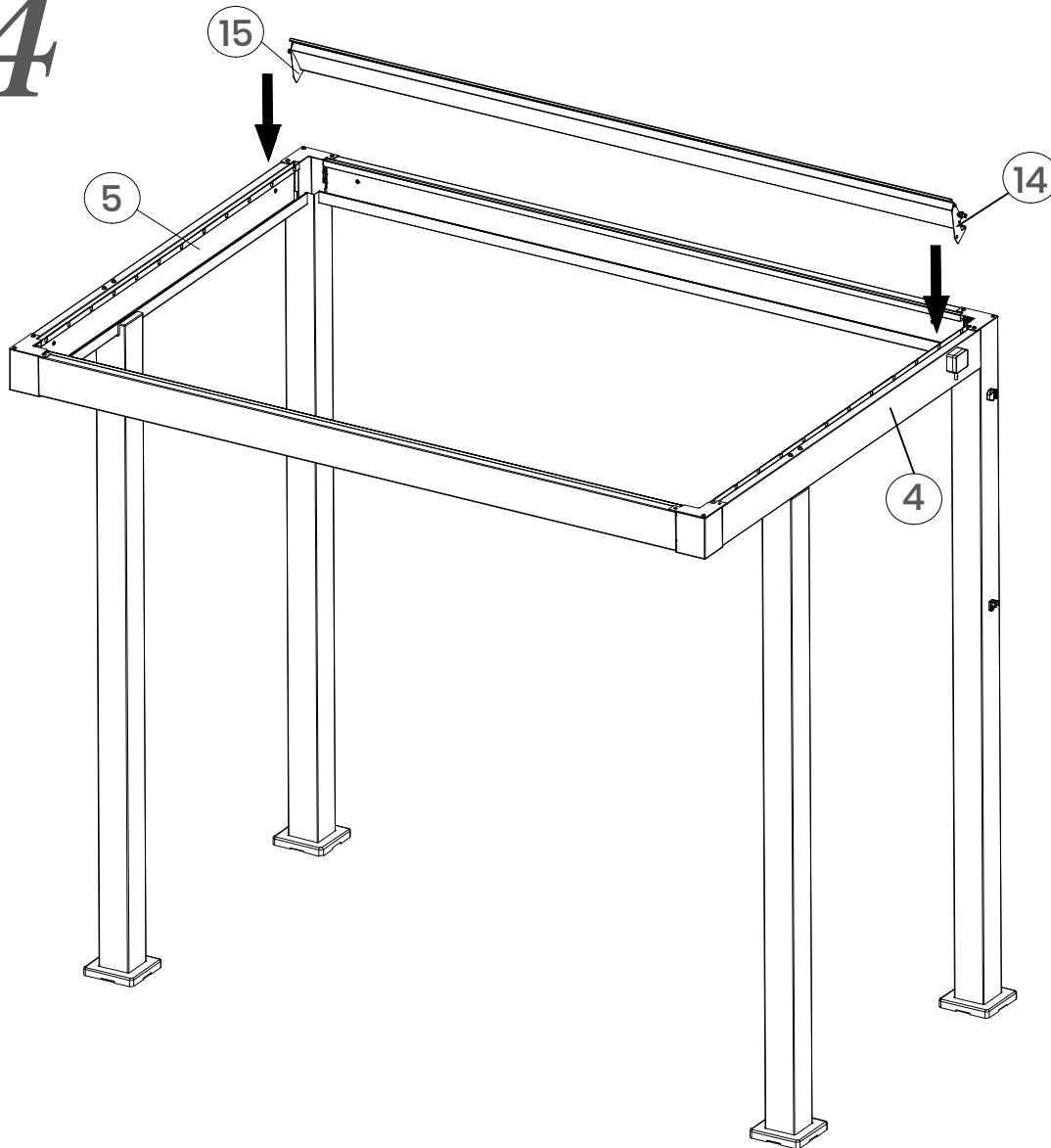

Note: The left and right direction of the louvers.

Remarque : Orientation gauche et droite des persiennes.

Nota: La dirección izquierda y derecha de las rejillas.

15

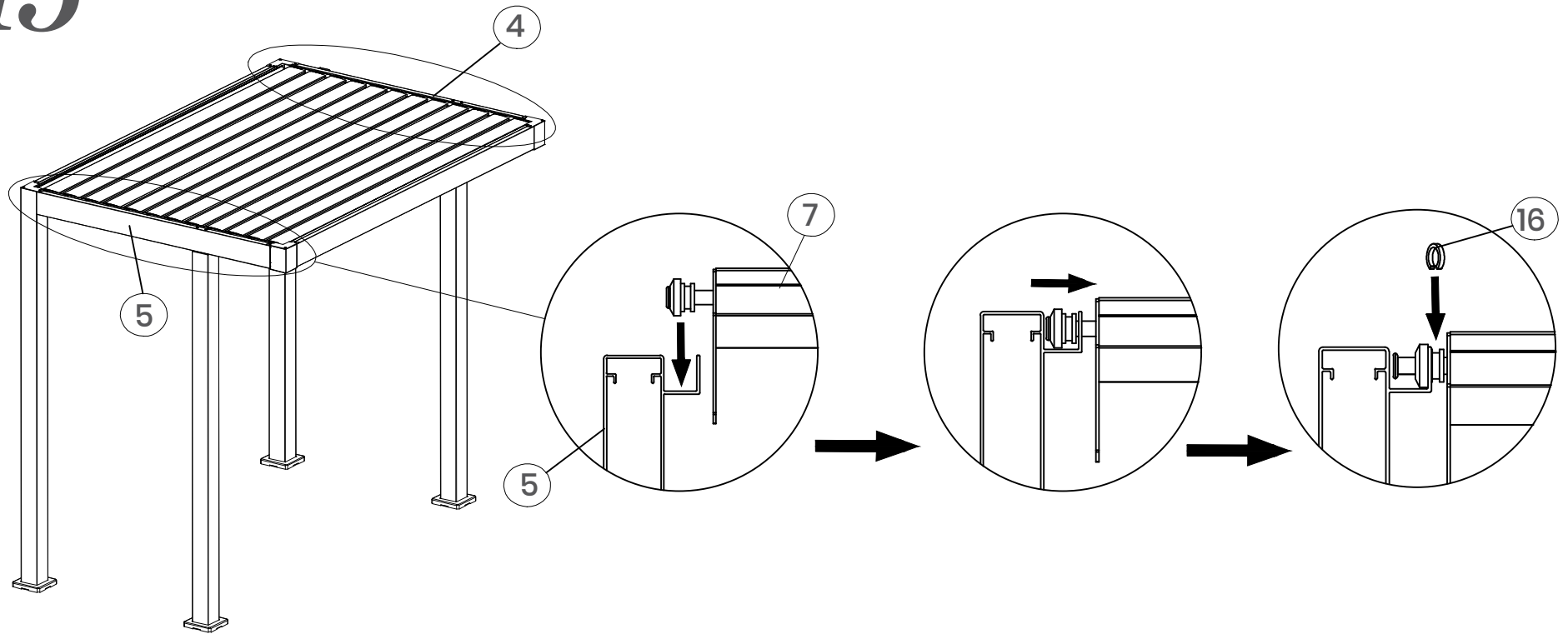

16

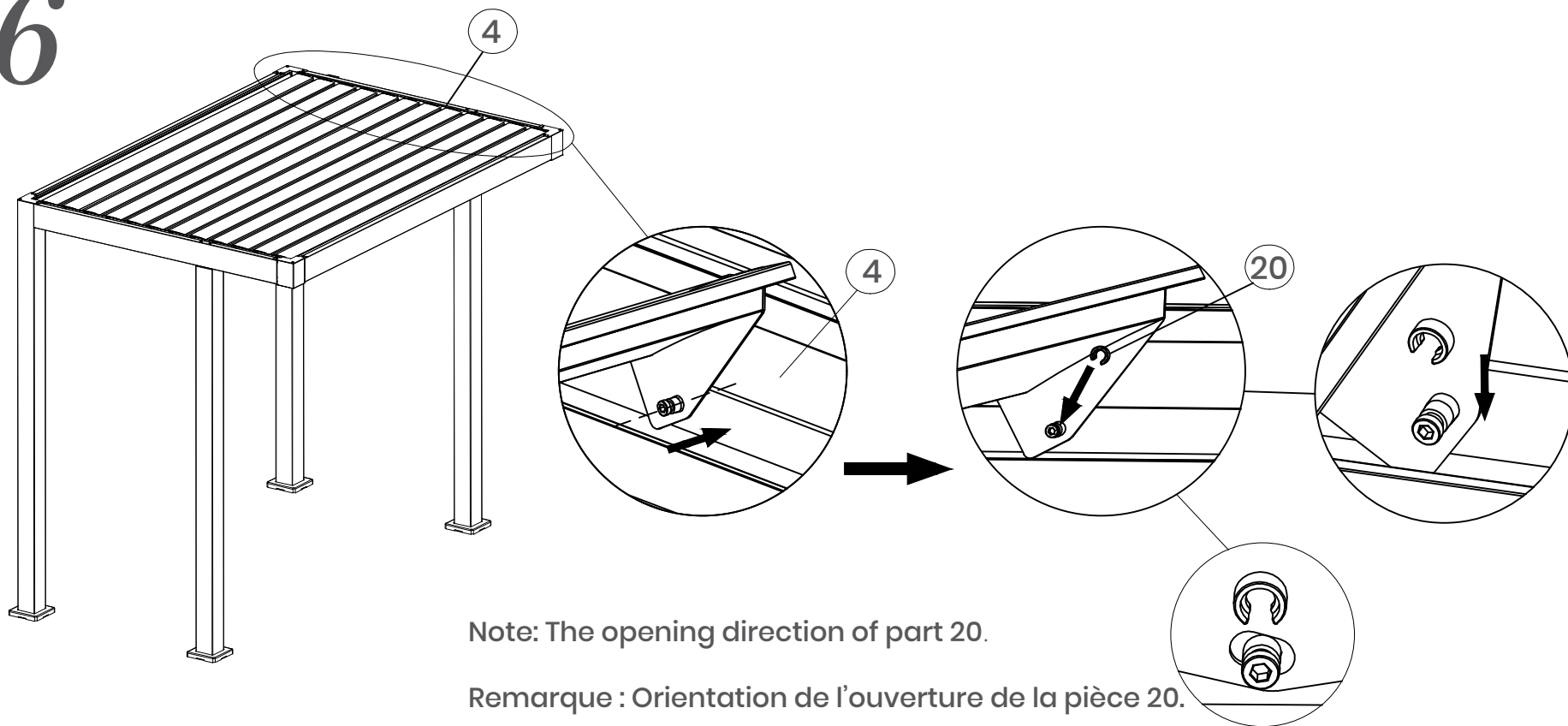

17

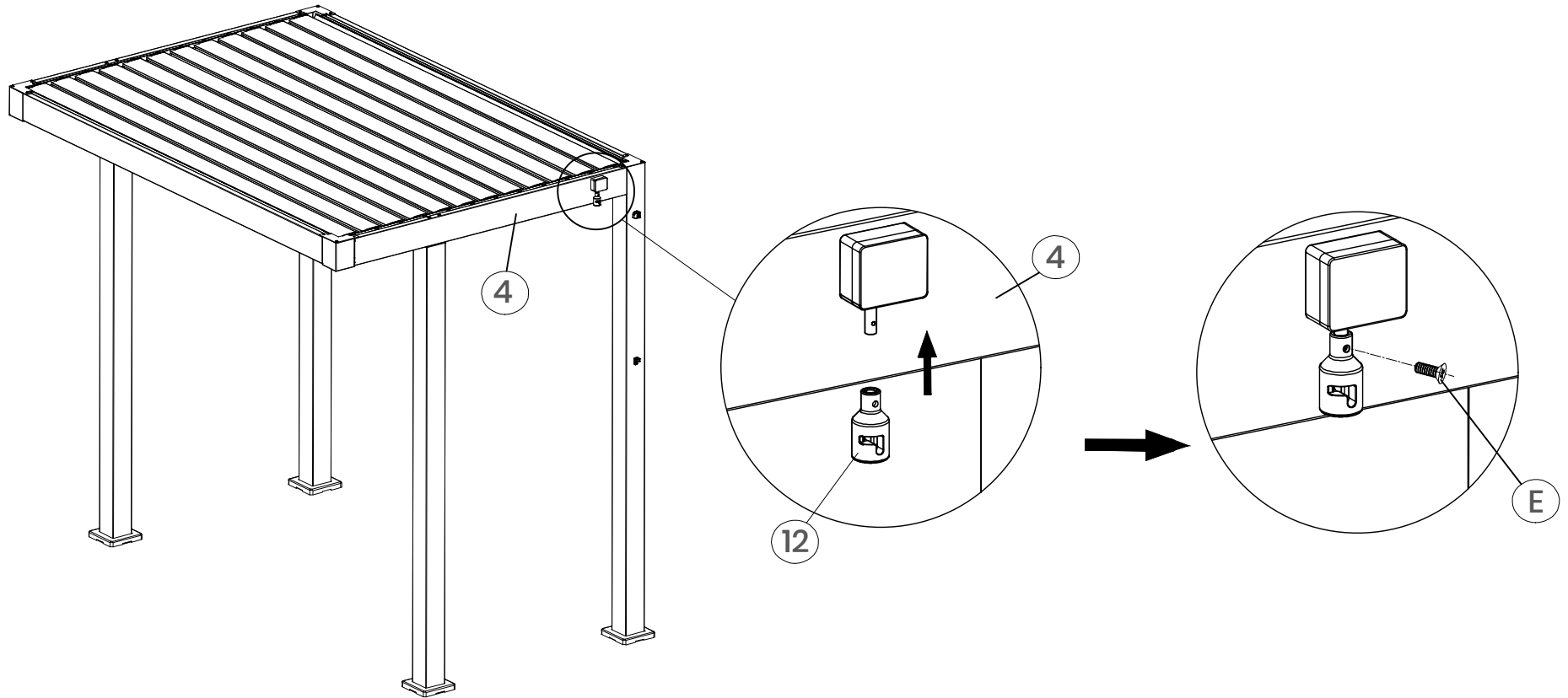

12

X1

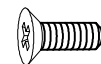

M5*18

E

X1

18

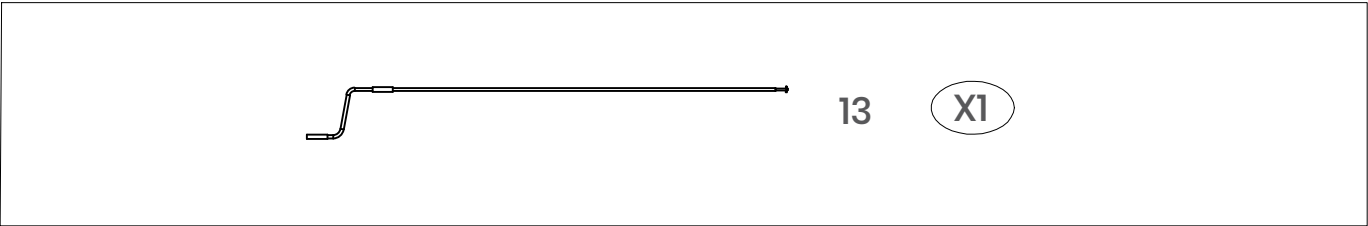
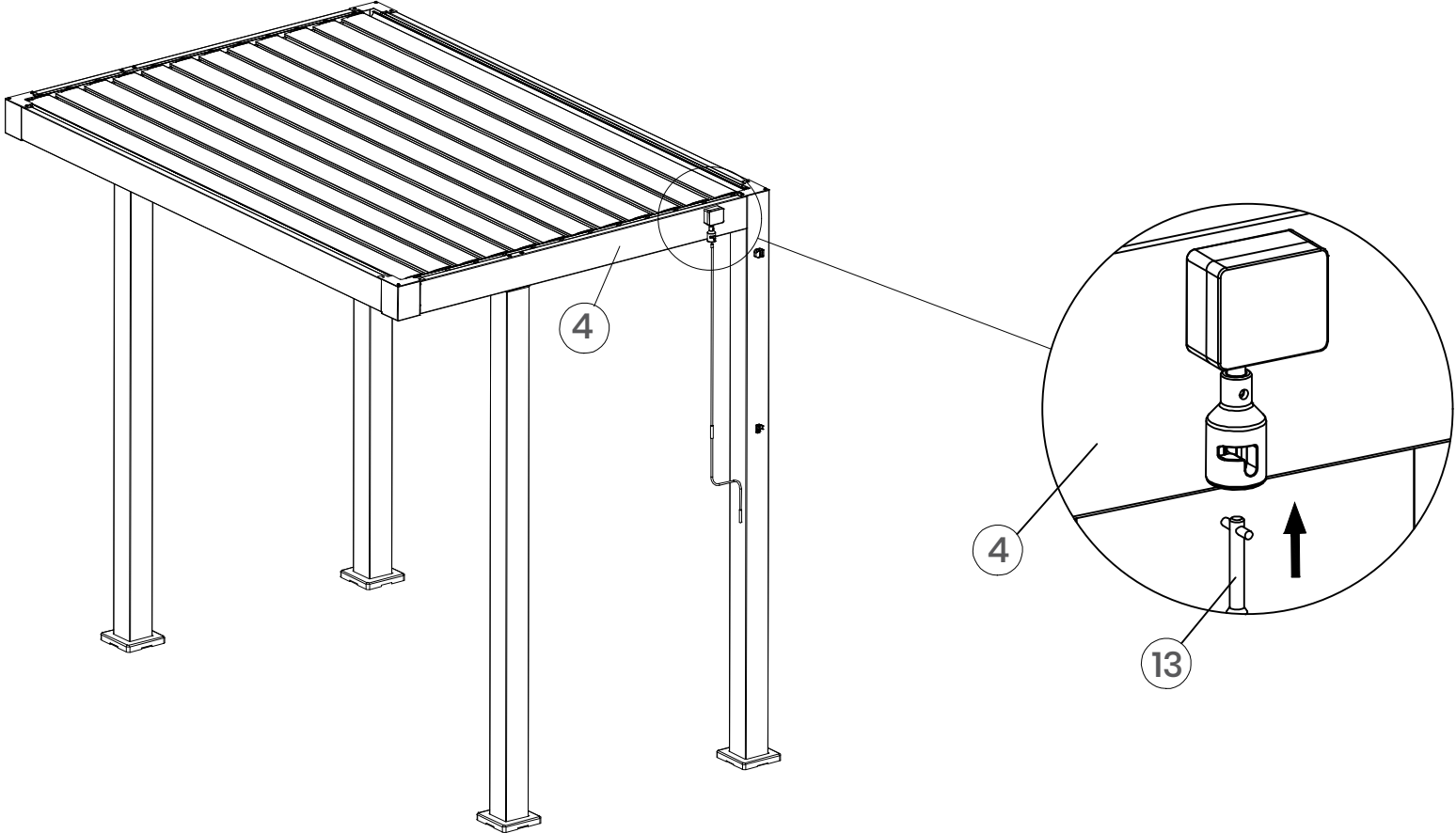

19

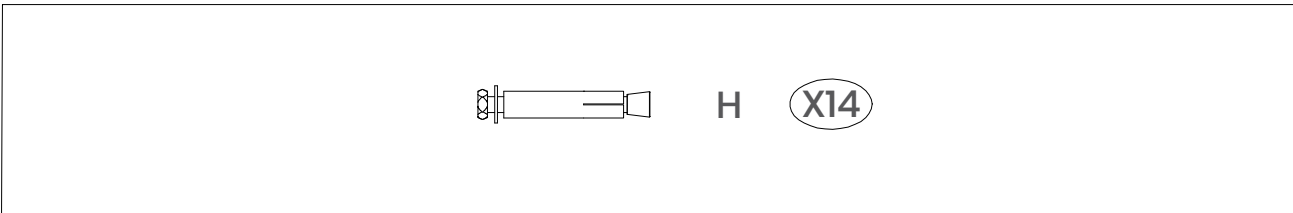
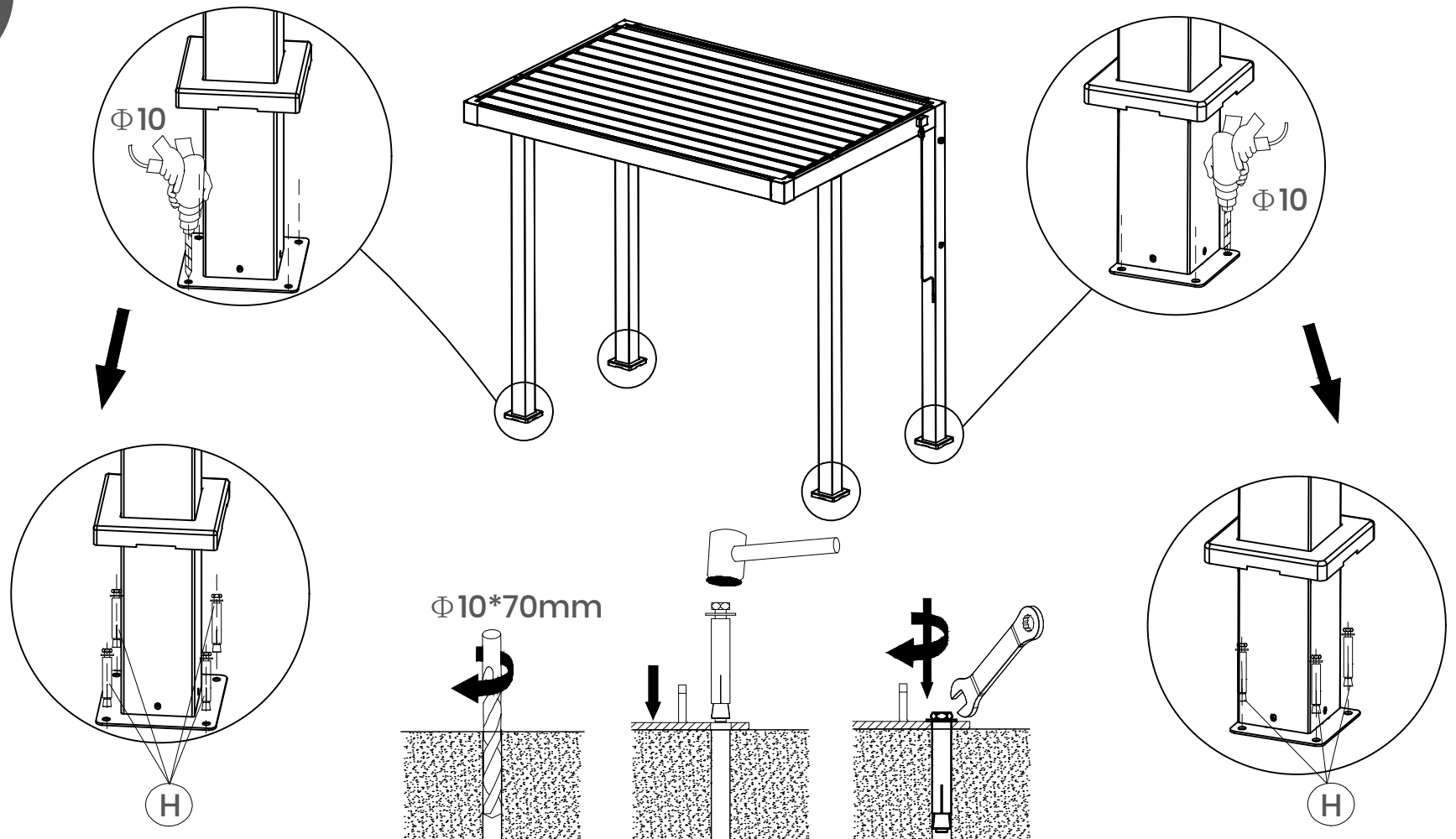

Distributed by:
Costco Wholesale Corporation
P.O. Box 34535
Seattle, WA 98124-1535
USA
1-800-774-2678
www.costco.com

Costco Wholesale UK Ltd /
Costco Online UK Ltd
Hartspring Lane
Watford, Herts
WD25 8JS
United Kingdom
01923 213113
www.costco.co.uk

Costco Wholesale Japan Ltd.
2 Kakuchi, 2 Gaiku, Kaneda-Nishi
361 Urikura, Kisarazu shi
Chiba, 292-0007 Japan
0570-200-800
www.costco.co.jp

Costco Wholesale Sweden AB
Box 614
114 11 Stockholm
Sweden
www.costco.se

Costco Wholesale Canada Ltd.*
415 W. Hunt Club Road
Ottawa, Ontario
K2E 1C5, Canada
1-800-463-3783
www.costco.ca

* faisant affaire au Québec sous
le nom les Entrepôts Costco

Costco Wholesale Spain S.L.U.
Polígono Empresarial Los Gavilanes
C/ Agustín de Betancourt, 17
28906 Getafe (Madrid) España
NIF: B86509460
900 111 155
www.costco.es

Costco Wholesale Korea, Ltd.
40, Iljik-ro
Gwangmyeong-si
Gyeonggi-do, 14347, Korea
1899-9900
www.costco.co.kr

Importado por:
Importadora Primex S.A. de C.V.
Blvd. Magnocentro No. 4
San Fernando La Herradura
Huixquilucan, Estado de México
C.P. 52765
RFC: IPR-930907-S70
(55)-5246-5500
www.costco.com.mx

Costco Wholesale Iceland ehf.
Kauptún 3-7, 210 Gardabaer
Iceland
www.costco.is

Costco Wholesale New Zealand Limited
2 Gunton Drive
Westgate
Auckland 0814
New Zealand
www.costco.co.nz

Costco Wholesale Australia Pty Ltd
17-21 Parramatta Road
Lidcombe NSW 2141
Australia
www.costco.com.au

Costco France
1 avenue de Bréhat
91140 Villebon-sur-Yvette
France
01 80 45 01 10
www.costco.fr

Costco (China) Investment Co., Ltd.
Room 01 Mezzanine
No. 5178, Kang Xin Highway
Pudong New District
Shanghai
China 201315
+86-21-6257-7065

MADE IN CHINA
FABRIQUÉ EN CHINE
HECHO EN CHINA